

Datasheet

WMA_series

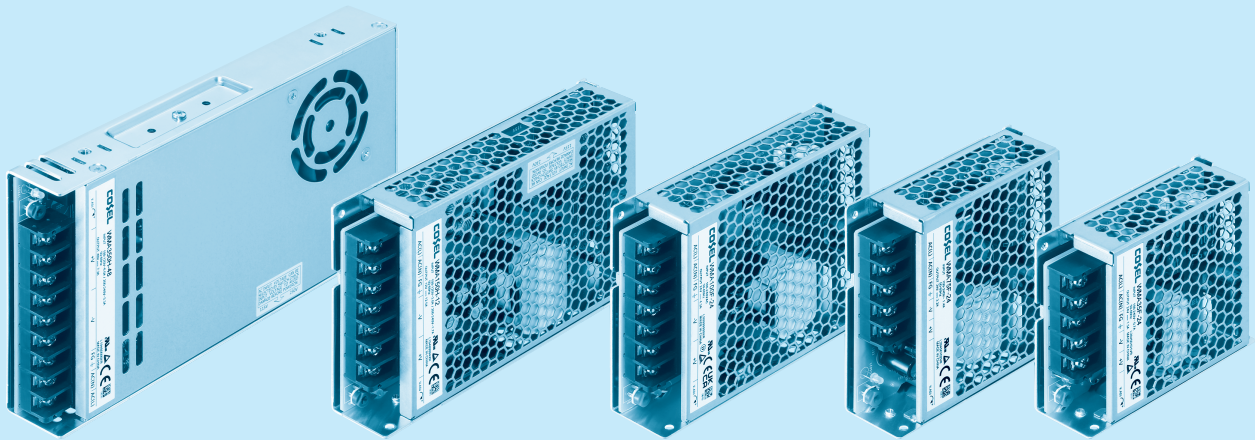

WMA-series



Feature

For medical electric equipment
(ANSI/AAMI ES60601-1, EN60601-1 3rd)
Medical Isolation Grade 2MOPP
4kV isolation
Low-profile
Economical design
Complies with SEMI F47(See Instruction Manual)

Safety agency approvals

ANSI/AAMI ES60601-1, EN60601-1 3rd,
C-UL (CAN/CSA-C22.2 No.60601-1),
UL62368-1, EN62368-1,
C-UL (CAN/CSA-C22.2 No.62368-1),
EN61558-2-16 (OVC III)

CE marking

Low Voltage Directive
RoHS Directive

UKCA marking

Electrical Equipment Safety Regulations
RoHS Regulations

5-year warranty (See Instruction Manual)

EMI

Complies with CISPR11-B, CISPR32-B, EN55011-B,
EN55032-B, FCC Part 15-B, FCC Part 18-B

EMS Compliance : EN61204-3, EN61000-6-2 IEC60601-1-2 (2014), EN60601-1-2 (2015)

EN61000-4-2
EN61000-4-3
EN61000-4-4
EN61000-4-5
EN61000-4-6
EN61000-4-8
EN61000-4-11

WMA35F

WM A 35 F - □ - □
 ① ② ③ ④ ⑤ ⑥

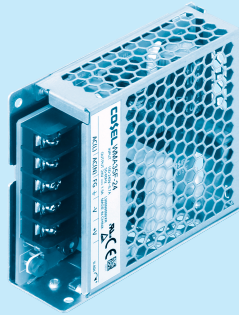

- ① Series name
- ② Single output
- ③ Output wattage
- ④ Universal input
- ⑤ Output voltage
- ⑥ Optional : *5
- C : With Coating
- G : Low leakage current
- J1 : VH(J.S.T.)connector type
- J4 : EP(Tyco)connector type
- T1 : Horizontal terminal block

* Make sure necessary tests will be carried out on your end equipment with the power supply installed in accordance with any required EMC/EMI regulations.

MODEL	WMA35F-5	WMA35F-12	WMA35F-24	WMA35F-48
MAX OUTPUT WATTAGE[W]	35	36	36	38.4
DC OUTPUT	5V 7A	12V 3A	24 1.5A	48V 0.8A

SPECIFICATIONS

	MODEL	WMA35F-5	WMA35F-12	WMA35F-24	WMA35F-48	
INPUT	VOLTAGE[V]	AC85 - 264 1φ				
	CURRENT[A]	ACIN 115V	0.7			
		ACIN 230V	0.4			
	FREQUENCY[Hz]	50/60 (47-63)				
	EFFICIENCY[%]	ACIN 115V	79typ	84typ	86typ	87typ
		ACIN 230V	82typ	86typ	88typ	89typ
	INRUSH CURRENT[A]	ACIN 115V	20typ Ta=25°C (at cold start)			
ACIN 230V		40typ Ta=25°C (at cold start)				
LEAKAGE CURRENT[mA]	ACIN 115V	0.3max				
	ACIN 240V	0.5max				
OUTPUT	VOLTAGE[V]	5	12	24	48	
	CURRENT[A]	7	3	1.5	0.8	
	WATTAGE[W]	35	36	36	38.4	
	LINE REGULATION[mV] *1	50max	120max	240max	480max	
	LOAD REGULATION[mV] *1	50max	120max	240max	480max	
	RIPPLE NOISE [mVp-p] *2 Io=100%	150max (Bandwidth 20MHz)				
	TEMPERATURE REGULATION[mV] 0~+50°C	100max	180max	360max	720max	
	START-UP TIME[ms]	ACIN 115V	100typ			
		ACIN 230V				
	HOLD-UP TIME[ms]	ACIN 115V	20typ			
ACIN 230V		60typ				
OUTPUT VOLTAGE ADJUSTMENT RANGE[V]	4.5 to 5.5	10.8 to 13.2	21.6 to 26.4	43.2 to 52.8		
OUTPUT VOLTAGE SETTING[V]	4.9 to 5.3	11.75 to 12.25	23.5 to 24.5	47.0 to 49.0		
PROTECTION CIRCUIT AND OTHERS	OVERCURRENT PROTECTION [A]	Works over 105% of rating and recovers automatically				
	OVERVOLTAGE PROTECTION[V]	5.75 to 7.00	13.8 to 16.8	27.6 to 33.6	54.0 to 67.2	
	OPERATING INDICATION	LED (Green)				
ISOLATION	INPUT-OUTPUT	AC4,000V 1minute, Cutoff current = 10mA, DC500V 50MΩ min (At Room Temperature) 2MOPP				
	INPUT-FG	AC2,000V 1minute, Cutoff current = 10mA, DC500V 50MΩ min (At Room Temperature) 1MOPP				
	OUTPUT-FG	AC500V 1minute, Cutoff current = 100mA, DC500V 50MΩ min (At Room Temperature)				
ENVIRONMENT	OPERATING TEMP., HUMID. *3	-20 to +70°C, 20 - 90%RH (Non condensing)				
	STORAGE TEMP., HUMID.	-20 to +75°C, 20 - 90%RH (Non condensing)				
	VIBRATION	10 - 55Hz, 19.6m/s ² (2G) , 3minutes period, 60minutes each along X, Y and Z axis				
	IMPACT	196.1m/s ² (20G) , 11ms, once each X, Y and Z axis				
SAFETY AND EMC	AGENCY APPROVALS	UL62368-1, C-UL (equivalent to CAN/CSA-C22.2 No.62368-1), EN62368-1, ANSI/AAMI ES60601-1, C-UL (equivalent to CAN/CSA-C22.2 No.60601-1), EN60601-1 3rd, EN61558-2-16 (OVC III), Complies with IEC60601-1-2 4th Ed.				
	EMC EMISSION	Complies with CISPR11-B, CISPR32-B, EN55011-B, EN55032-B, FCC Part 15-B, FCC Part 18-B				
	EMC IMMUNITY	Complies with EN61000-4-2, 3, 4, 5, 6, 8, 11				
	HARMONIC ATTENUATOR *4	Complies with IEC61000-3-2 (Class A) No built-in active PFC				
OTHERS	CASE SIZE/WEIGHT	30X82X99mm (W×H×D) / 200g max				
	COOLING METHOD	Convection				
WARRANTY	WARRANTY	*5	5 years (subject to the operating conditions)			

*1 Consult us about dynamic load and input response. Measure the output voltage by using the average mode of the tester to deal with the burst operation at low (Io=0~20%Atp) load.

*2 This is the result of measurement of the testing board with capacitors of 47μF and 0.1μF placed at 150 mm from the output terminals by a 20MHz oscilloscope or a ripple-noise meter equivalent to Keisoku-GikenRM104.

When the load factor is low (Io=0~20%Atp), the switching power loss is reduced by burst operation, which will cause ripple noise to go beyond the specifications.

*3 Output power derating is required. Refer to "Derating"

*4 Please contact us about another class. When two or more units are operating it may not comply with the IEC61000-3-2. Please contact us for details.

*5 Consult us about details.

*6 The listed options may affect the published standard specifications. Please contact us for detailed product specifications and safety approvals.

* All parameters not specially mentioned are measured at ACIN 230V, rated load and 25°C of ambient temperature.

* Do not use the power supply in overcurrent conditions or in unspecified input voltage ranges. Otherwise the internal components may be damaged.

* Parallel operation is not possible with this model.

* Acoustic noise may be heard from the power supply when used for pulse load.

External view

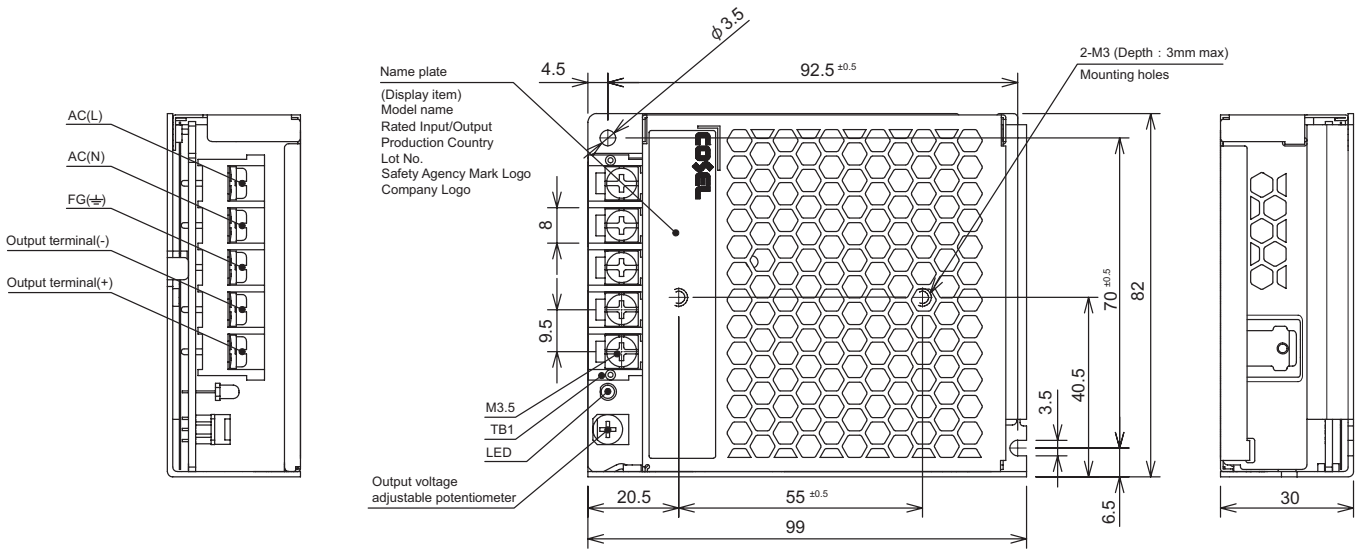

- ※ Dimensions in mm
- ※ Tolerance : ±1
- ※ Weight : 200g max
- ※ PCB Material/thickness : CEM-3 / 1.6mm
- ※ Chassis material : Aluminum
- ※ Case material : Hot-dip galvanized steel board (SGCC)
- ※ Mounting torque : 0.49N · m max
- ※ TB1 screw tightening torque : 1N · m max
- ※ Please connect safety ground to the unit in 2-M3 holes.

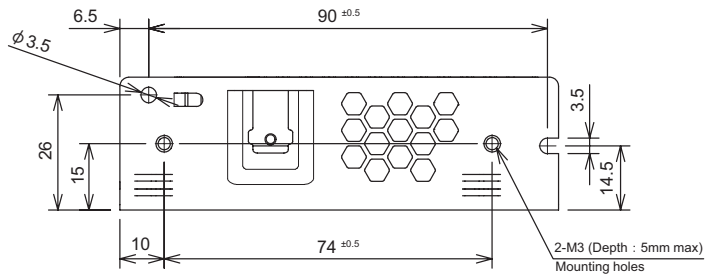

Derating Curve

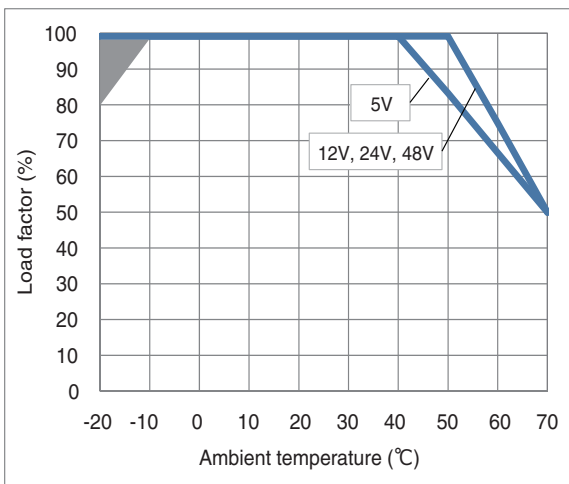

*The shaded area is the derating required at start-up.

Fig.1 Derating curve depending on ambient temperature

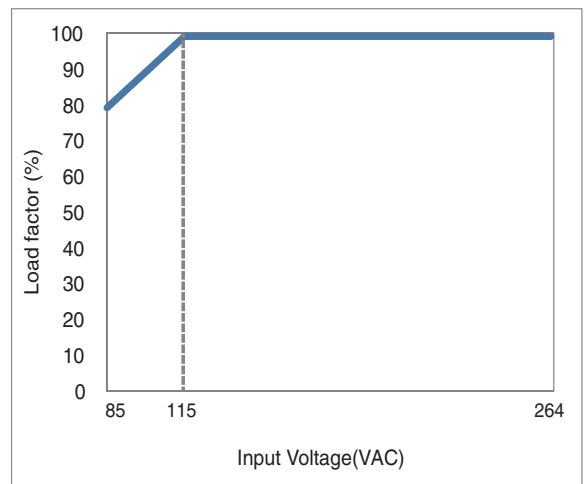
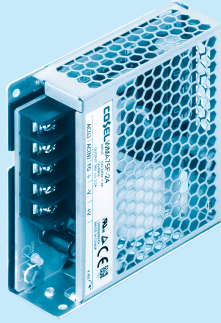

Fig.2 Derating curve depending on input voltage

■ The ambient temperature should be measured 5 to 10 cm away from the power supply so that it won't be influenced by the heat from the power supply. Please consult us for more details.

WMA75F

① WM ② A ③ 75 ④ F ⑤ -□ ⑥ -□



- ① Series name
- ② Single output
- ③ Output wattage
- ④ Universal input
- ⑤ Output voltage
- ⑥ Optional : *6
- C : With Coating
- G : Low leakage current
- J1 : VH(J.S.T.)connector type
- J4 : EP(Tyco)connector type
- T1 : Horizontal terminal block

* Make sure necessary tests will be carried out on your end equipment with the power supply installed in accordance with any required EMC/EMI regulations.

MODEL	WMA75F-12	WMA75F-24	WMA75F-48
MAX OUTPUT WATTAGE[W]	72	76.8	76.8
DC OUTPUT	12V 6A	24V 3.2A	48V 1.6A

SPECIFICATIONS

	MODEL	WMA75F-12	WMA75F-24	WMA75F-48	
INPUT	VOLTAGE[V]	AC85 - 264 1φ			
	CURRENT[A]	ACIN 115V	1.4		
		ACIN 230V	0.8		
	FREQUENCY[Hz]	50/60 (47-63)			
	EFFICIENCY[%]	ACIN 115V	84typ	87typ	88typ
		ACIN 230V	86typ	89typ	90typ
	INRUSH CURRENT[A]	ACIN 115V	20typ Ta=25°C (at cold start)		
ACIN 230V		40typ Ta=25°C (at cold start)			
LEAKAGE CURRENT[ma]	ACIN 115V	0.3max			
	ACIN 240V	0.5max			
OUTPUT	VOLTAGE[V]	12	24	48	
	CURRENT[A]	6	3.2	1.6	
	WATTAGE[W]	72	76.8	76.8	
	LINE REGULATION[mV] *1	120max	240max	480max	
	LOAD REGULATION[mV] *1	120max	240max	480max	
	RIPPLE NOISE [mVp-p] *2 Io=100%	150max (Bandwidth 20MHz)			
	TEMPERATURE REGULATION[mV] 0~+50°C	180max	360max	720max	
	START-UP TIME[ms]	ACIN 115V	100typ		
		ACIN 230V			
	HOLD-UP TIME[ms]	ACIN 115V	15typ		
ACIN 230V		60typ			
OUTPUT VOLTAGE ADJUSTMENT RANGE[V]	10.8 to 13.2	21.6 to 26.4	43.2 to 52.8		
OUTPUT VOLTAGE SETTING[V]	11.75 to 12.25	23.5 to 24.5	47.0 to 49.0		
PROTECTION CIRCUIT AND OTHERS	OVERCURRENT PROTECTION [A]	Works over 105% of rating and recovers automatically			
	OVERVOLTAGE PROTECTION[V]	13.8 to 16.8	27.6 to 33.6	55.2 to 67.2	
	OPERATING INDICATION	LED (Green)			
ISOLATION	INPUT-OUTPUT	AC4,000V 1minute, Cutoff current = 10mA, DC500V 50MΩ min (At Room Temperature) 2MOPP			
	INPUT-FG	AC2,000V 1minute, Cutoff current = 10mA, DC500V 50MΩ min (At Room Temperature) 1MOPP			
	OUTPUT-FG	AC500V 1minute, Cutoff current = 100mA, DC500V 50MΩ min (At Room Temperature)			
ENVIRONMENT	OPERATING TEMP., HUMID. *3	-20 to +70°C, 20-90%RH (Non condensing)			
	STORAGE TEMP., HUMID.	-20 to +75°C, 20-90%RH (Non condensing)			
	VIBRATION	10-55Hz, 19.6m/s ² (2G) , 3minutes period, 60minutes each along X, Y and Z axis			
	IMPACT	196.1m/s ² (20G) , 11ms, once each X, Y and Z axis			
SAFETY AND EMC	AGENCY APPROVALS	UL62368-1, C-UL (equivalent to CAN/CSA-C22.2 No.62368-1), EN62368-1, ANSI/AAMI ES60601-1, C-UL (equivalent to CAN/CSA-C22.2 No.60601-1), EN60601-1 3rd, EN61558-2-16 (OVC III), Complies with IEC60601-1-2 4th Ed.			
	EMC EMISSION	Complies with CISPR11-B, CISPR32-B, EN55011-B, EN55032-B, FCC Part 15-B, FCC Part 18-B			
	EMC IMMUNITY	Complies with EN61000-4-2, 3, 4, 5, 6, 8, 11			
	HARMONIC ATTENUATOR *4	Complies with IEC61000-3-2 (Class A) No built-in active PFC			
OTHERS	CASE SIZE/WEIGHT	30X97X99mm (W×H×D) / 250g max			
	COOLING METHOD	Convection			
WARRANTY	WARRANTY *5	5 years (subject to the operating conditions)			

*1 Consult us about dynamic load and input response. Measure the output voltage by using the average mode of the tester to deal with the burst operation at low (Io=0~20%Atyp) load.
 *2 This is the result of measurement of the testing board with capacitors of 47μF and 0.1μF placed at 150 mm from the output terminals by a 20MHz oscilloscope or a ripple-noise meter equivalent to Keisoku-GikenRM104.
 When the load factor is low (Io=0~20%Atyp), the switching power loss is reduced by burst operation, which will cause ripple noise to go beyond the specifications.
 *3 Output power derating is required. Refer to "Derating"
 *4 Please contact us about another class. When two or more units are operating it may not comply with the IEC61000-3-2. Please contact us for details.

*5 Consult us about details.
 *6 The listed options may affect the published standard specifications. Please contact us for detailed product specifications and safety approvals.
 * All parameters not specially mentioned are measured at ACIN 230V, rated load and 25°C of ambient temperature.
 * Do not use the power supply in overcurrent conditions or in unspecified input voltage ranges. Otherwise the internal components may be damaged.
 * Parallel operation is not possible with this model.
 * Acoustic noise may be heard from the power supply when used for pulse load.

External view

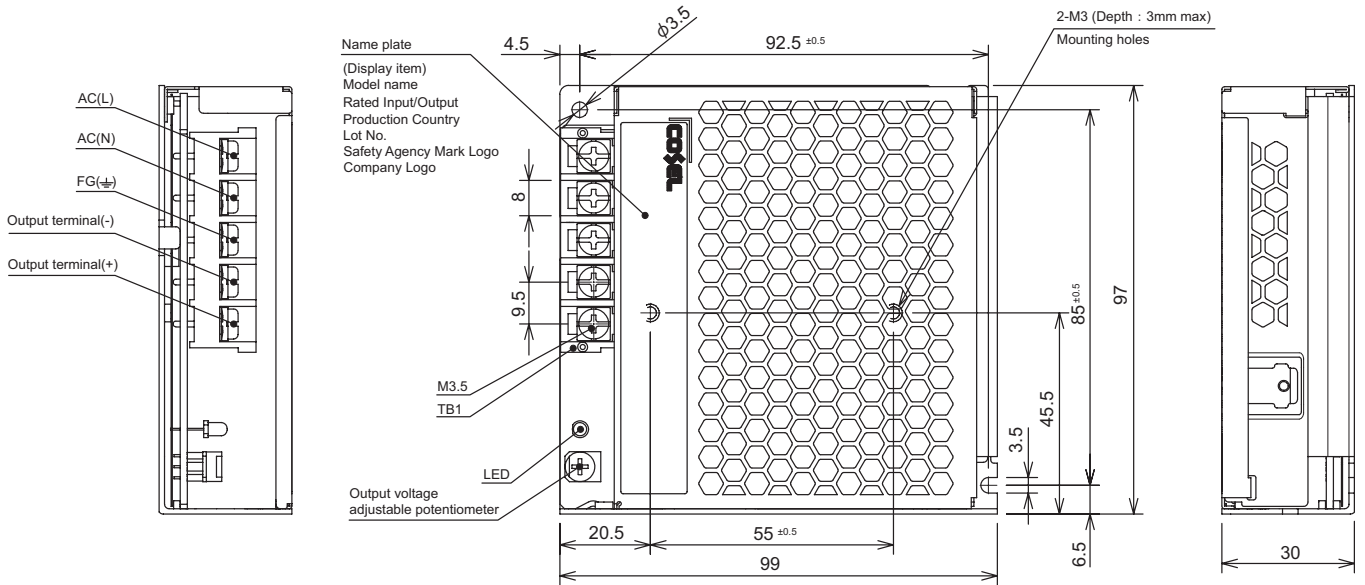

- ※ Dimensions in mm
- ※ Tolerance : ±1
- ※ Weight : 250g max
- ※ PCB Material/thickness : CEM-3 / 1.6mm
- ※ Chassis material : Aluminum
- ※ Case material : Hot-dip galvanized steel board (SGCC)
- ※ Mounting torque : 0.49N · m max
- ※ TB1 screw tightening torque : 1N · m max
- ※ Please connect safety ground to the unit in 2-M3 holes.

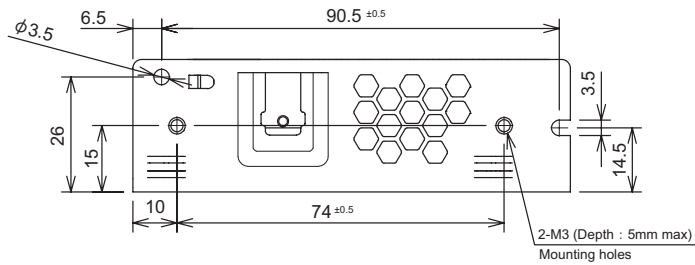

Derating Curve

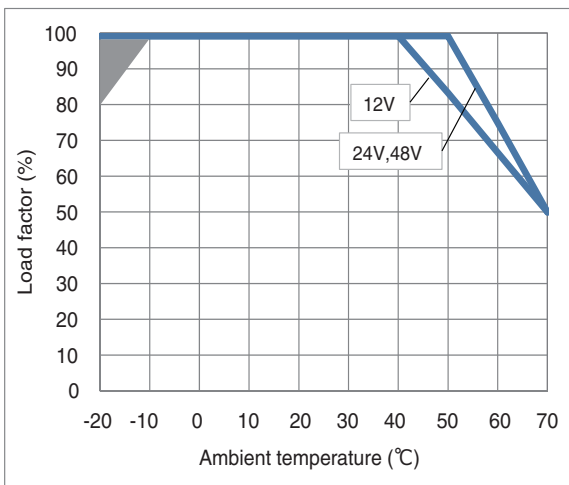

*The shaded area is the derating required at start-up.

Fig.1 Derating curve depending on ambient temperature

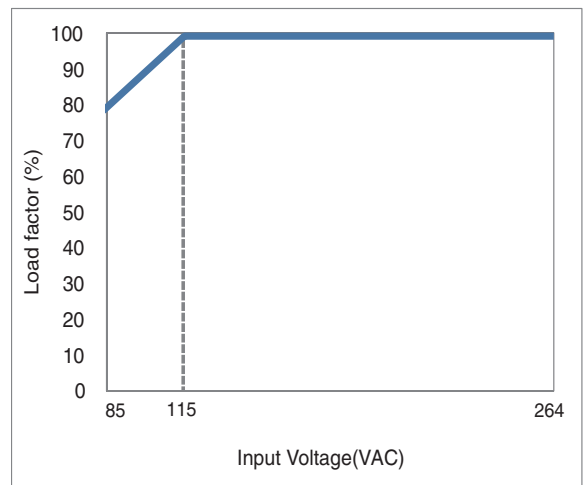
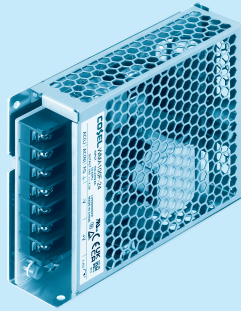

Fig.2 Derating curve depending on input voltage

■ The ambient temperature should be measured 5 to 10 cm away from the power supply so that it won't be influenced by the heat from the power supply. Please consult us for more details.

WMA100F

WM A 100 F - □ - □
 ① ② ③ ④ ⑤ ⑥



- ① Series name
- ② Single output
- ③ Output wattage
- ④ Universal input
- ⑤ Output voltage
- ⑥ Optional : *6
- C : With Coating
- G : Low leakage current
- J1 : VH(J.S.T.)connector type
- J4 : EP(Tyco)connector type
- T1 : Horizontal terminal block

* Make sure necessary tests will be carried out on your end equipment with the power supply installed in accordance with any required EMC/EMI regulations.

MODEL	WMA100F-12	WMA100F-24	WMA100F-48
MAX OUTPUT WATTAGE[W]	100.8	103.2	100.8
DC OUTPUT	12V 8.4A	24V 4.3A	48V 2.1A

SPECIFICATIONS

	MODEL	WMA100F-12	WMA100F-24	WMA100F-48	
INPUT	VOLTAGE[V]	AC85 - 264 1φ			
	CURRENT[A]	ACIN 115V	2.0		
		ACIN 230V	1.2		
	FREQUENCY[Hz]	50/60 (47-63)			
	EFFICIENCY[%]	ACIN 115V	84typ	87typ	88typ
		ACIN 230V	87typ	90typ	91typ
	INRUSH CURRENT[A]	ACIN 115V	40typ Ta=25°C (at cold start)		
ACIN 230V		60typ Ta=25°C (at cold start)			
LEAKAGE CURRENT[mA]	ACIN 115V	0.3max			
	ACIN 240V	0.5max			
OUTPUT	VOLTAGE[V]	12	24	48	
	CURRENT[A]	8.4	4.3	2.1	
	WATTAGE[W]	100.8	103.2	100.8	
	LINE REGULATION[mV] *1	120max	240max	480max	
	LOAD REGULATION[mV] *1	120max	240max	480max	
	RIPPLE NOISE [mVp-p] *2 Io=100%	150max (Bandwidth 20MHz)			
	TEMPERATURE REGULATION[mV]	0~+50°C	180max	360max	
	START-UP TIME[ms]	ACIN 115V	100typ		
		ACIN 230V			
	HOLD-UP TIME[ms]	ACIN 115V	10typ		
ACIN 230V		55typ			
OUTPUT VOLTAGE ADJUSTMENT RANGE[V]	10.8 to 13.2	21.6 to 26.4	43.2 to 52.8		
OUTPUT VOLTAGE SETTING[V]	11.75 to 12.25	23.5 to 24.5	47.0 to 49.0		
PROTECTION CIRCUIT AND OTHERS	OVERCURRENT PROTECTION [A]	Works over 105% of rating and recovers automatically			
	OVERVOLTAGE PROTECTION[V]	13.8 to 16.8	27.6 to 33.6	55.2 to 67.2	
	OPERATING INDICATION	LED (Green)			
ISOLATION	INPUT-OUTPUT	AC4,000V 1minute, Cutoff current = 10mA, DC500V 50MΩ min (At Room Temperature) 2MOPP			
	INPUT-FG	AC2,000V 1minute, Cutoff current = 10mA, DC500V 50MΩ min (At Room Temperature) 1MOPP			
	OUTPUT-FG	AC500V 1minute, Cutoff current = 100mA, DC500V 50MΩ min (At Room Temperature)			
ENVIRONMENT	OPERATING TEMP., HUMID. *3	-20 to +70°C, 20-90%RH (Non condensing)			
	STORAGE TEMP., HUMID.	-20 to +75°C, 20-90%RH (Non condensing)			
	VIBRATION	10-55Hz, 19.6m/s ² (2G) , 3minutes period, 60minutes each along X, Y and Z axis			
	IMPACT	196.1m/s ² (20G) , 11ms, once each X, Y and Z axis			
SAFETY AND EMC	AGENCY APPROVALS	UL62368-1, C-UL (equivalent to CAN/CSA-C22.2 No.62368-1), EN62368-1, ANSI/AAMI ES60601-1, C-UL (equivalent to CAN/CSA-C22.2 No.60601-1), EN60601-1 3rd, EN61558-2-16 (OVC III), Complies with IEC60601-1-2 4th Ed.			
	EMC EMISSION	Complies with CISPR11-B, CISPR32-B, EN55011-B, EN55032-B, FCC Part 15-B, FCC Part 18-B			
	EMC IMMUNITY	Complies with EN61000-4-2, 3, 4, 5, 6, 8, 11			
	HARMONIC ATTENUATOR *4	Complies with IEC61000-3-2 (Class A) No built-in active PFC			
OTHERS	CASE SIZE/WEIGHT	30X97X129mm (WXHXD) / 300g max			
	COOLING METHOD	Convection			
WARRANTY	WARRANTY *5	5 years (subject to the operating conditions)			

*1 Consult us about dynamic load and input response. Measure the output voltage by using the average mode of the tester to deal with the burst operation at low (Io=0~20%Atyp) load.

*2 This is the result of measurement of the testing board with capacitors of 47μF and 0.1μF placed at 150 mm from the output terminals by a 20MHz oscilloscope or a ripple-noise meter equivalent to Keisoku-GikenRM104.

When the load factor is low (Io=0~20%Atyp), the switching power loss is reduced by burst operation, which will cause ripple noise to go beyond the specifications.

*3 Output power derating is required. Refer to "Derating"

*4 Please contact us about another class. When two or more units are operating it may not comply with the IEC61000-3-2. Please contact us for details.

*5 Consult us about details.

*6 The listed options may affect the published standard specifications. Please contact us for detailed product specifications and safety approvals.

* All parameters not specially mentioned are measured at ACIN 230V, rated load and 25°C of ambient temperature.

* Do not use the power supply in overcurrent conditions or in unspecified input voltage ranges. Otherwise the internal components may be damaged.

* Parallel operation is not possible with this model.

* Acoustic noise may be heard from the power supply when used for pulse load.

External view

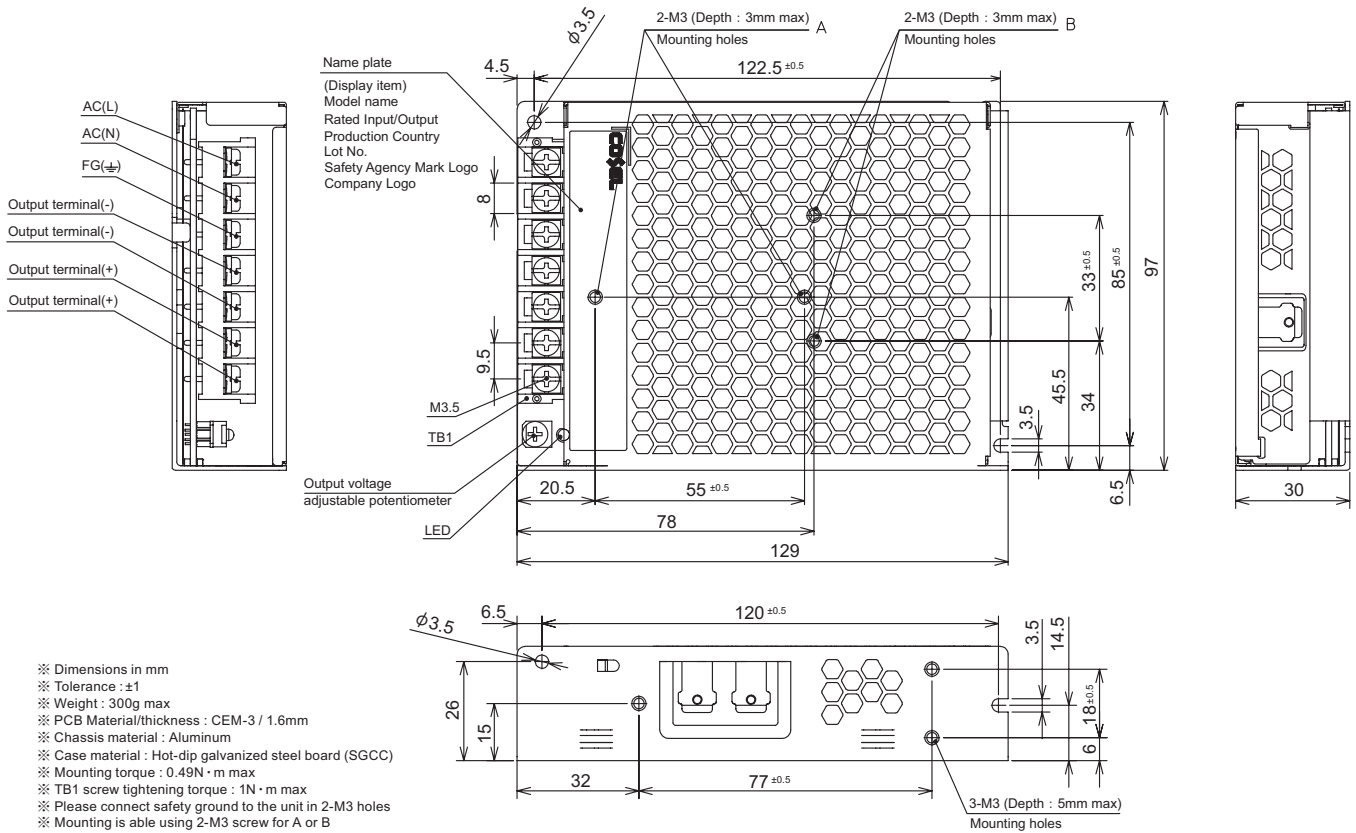

Derating Curve

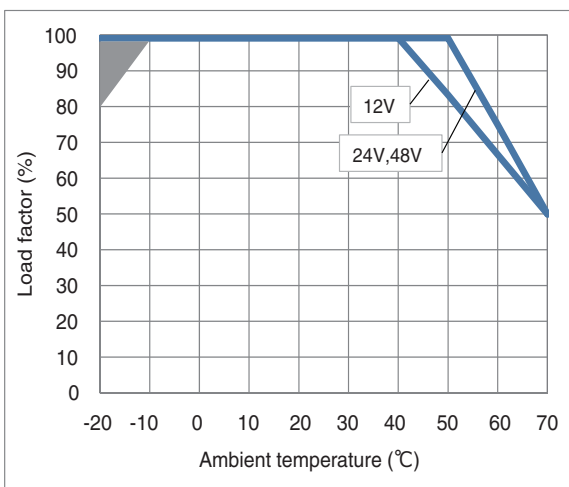

*The shaded area is the derating required at start-up.

Fig.1 Derating curve depending on ambient temperature

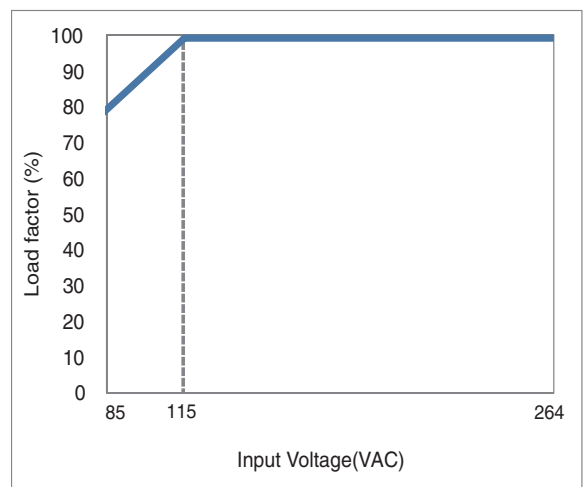

Fig.2 Derating curve depending on input voltage

■ The ambient temperature should be measured 5 to 10 cm away from the power supply so that it won't be influenced by the heat from the power supply. Please consult us for more details.

WMA150H

① WM ② A ③ 150 ④ H ⑤ -□ ⑥ -□



- ① Series name
- ② Single output
- ③ Output wattage
- ④ Input voltage selectable by switch
- ⑤ Output voltage
- ⑥ Optional : *5
- C : With Coating
- G : Low leakage current
- T1 : Horizontal terminal block

*Make sure necessary tests will be carried out on your end equipment with the power supply installed in accordance with any required EMC/EMI regulations.

MODEL	WMA150H-12	WMA150H-24	WMA150H-48
MAX OUTPUT WATTAGE[W]	150	156	158.4
DC OUTPUT	12V 12.5A	24V 6.5A	48V 3.3A

SPECIFICATIONS

	MODEL	WMA150H-12	WMA150H-24	WMA150H-48	
INPUT	VOLTAGE[V]	AC85 - 132 1φ/AC170 - 264 1φ (Selectable by switch)			
	CURRENT[A]	ACIN 115V	3.0		
		ACIN 230V	1.7		
	FREQUENCY[Hz]	50/60 (47-63)			
	EFFICIENCY[%]	ACIN 115V	85typ	89typ	90typ
		ACIN 230V	86typ	90typ	91typ
	INRUSH CURRENT[A]	ACIN 115V	40typ Ta=25°C (at cold start)		
ACIN 230V		40typ Ta=25°C (at cold start)			
LEAKAGE CURRENT[mA]	ACIN 115V	0.3max			
	ACIN 240V	0.5max			
OUTPUT	VOLTAGE[V]	12	24	48	
	CURRENT[A]	12.5	6.5	3.3	
	WATTAGE[W]	150	156	158.4	
	LINE REGULATION[mV] *1	120max	240max	480max	
	LOAD REGULATION[mV] *1	120max	240max	480max	
	RIPPLE NOISE [mVp-p] *2 Io=100%	150max (Bandwidth 20MHz)			
	TEMPERATURE REGULATION[mV] 0~+50°C	180max	360max	720max	
	START-UP TIME[ms]	ACIN 115V	500typ		
		ACIN 230V	500typ		
	HOLD-UP TIME[ms]	ACIN 115V	35typ		
ACIN 230V		40typ			
OUTPUT VOLTAGE ADJUSTMENT RANGE[V]	10.8 to 13.2	21.6 to 26.4	43.2 to 52.8		
OUTPUT VOLTAGE SETTING[V]	11.75 to 12.25	23.5 to 24.5	47.0 to 49.0		
PROTECTION CIRCUIT AND OTHERS	OVERCURRENT PROTECTION [A]	Works over 105% of rating and recovers automatically			
	OVERVOLTAGE PROTECTION[V]	13.8 to 16.8	27.6 to 33.6	55.2 to 67.2	
	OPERATING INDICATION	LED (Green)			
ISOLATION	INPUT-OUTPUT	AC4,000V 1minute, Cutoff current = 10mA, DC500V 50MΩ min (At Room Temperature) 2MOPP			
	INPUT-FG	AC2,000V 1minute, Cutoff current = 10mA, DC500V 50MΩ min (At Room Temperature) 1MOPP			
	OUTPUT-FG	AC500V 1minute, Cutoff current = 100mA, DC500V 50MΩ min (At Room Temperature)			
ENVIRONMENT	OPERATING TEMP.,HUMID. *3	-20 to +70°C, 20-90%RH (Non condensing)			
	STORAGE TEMP.,HUMID.	-20 to +75°C, 20-90%RH (Non condensing)			
	VIBRATION	10 - 55Hz, 19.6m/s ² (2G) , 3minutes period, 60minutes each along X, Y and Z axis			
	IMPACT	196.1m/s ² (20G) , 11ms, once each X, Y and Z axis			
SAFETY AND EMC	AGENCY APPROVALS	UL62368-1, C-UL (equivalent to CAN/CSA-C22.2 No.62368-1), EN62368-1, ANSI/AAMI ES60601-1, C-UL (equivalent to CAN/CSA-C22.2 No.60601-1), EN60601-1 3rd, EN61558-2-16 (OVC III), Complies with IEC60601-1-2 4th Ed.			
	EMC EMISSION	Complies with CISPR11-B, CISPR32-B, EN55011-B, EN55032-B, FCC Part 15-B, FCC Part 18-B			
	EMC IMMUNITY	Complies with EN61000-4-2, 3, 4, 5, 6, 8, 11			
OTHERS	CASE SIZE/WEIGHT	30x97x159mm (WxHxD) / 500g max			
	COOLING METHOD	Convection			
WARRANTY	WARRANTY *4	5 years (subject to the operating conditions)			

*1 Consult us about dynamic load and input response. Measure the output voltage by using the average mode of the tester to deal with the burst operation at low (Io=0~20%Atyp) load.

*2 This is the result of measurement of the testing board with capacitors of 47μF and 0.1μF placed at 150 mm from the output terminals by a 20MHz oscilloscope or a ripple-noise meter equivalent to Keisoku-GikenRM104.

When the load factor is low (Io=0~20%Atyp), the switching power loss is reduced by burst operation, which will cause ripple noise to go beyond the specifications.

*3 Output power derating is required. Refer to "Derating"

*4 Consult us about details.

*5 The listed options may affect the published standard specifications. Please contact us for detailed product specifications and safety approvals.

* All parameters not specially mentioned are measured at ACIN 230V, rated load and 25°C of ambient temperature.

* Do not use the power supply in overcurrent conditions or in unspecified input voltage ranges. Otherwise the internal components may be damaged.

* Parallel operation is not possible with this model.

* Acoustic noise may be heard from the power supply when used for pulse load.

External view

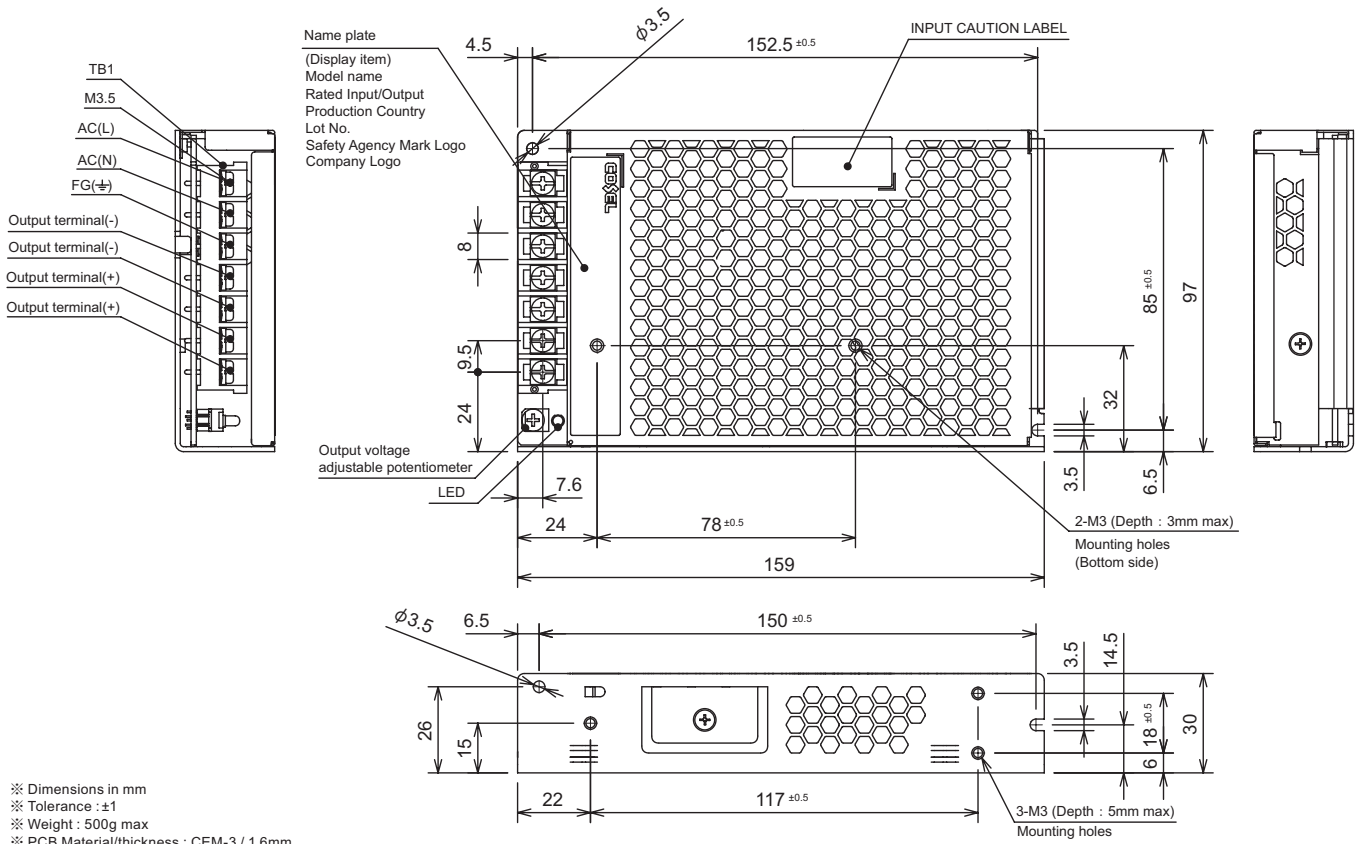

- ※ Dimensions in mm
- ※ Tolerance : ±1
- ※ Weight : 500g max
- ※ PCB Material/thickness : CEM-3 / 1.6mm
- ※ Chassis material : Aluminum
- ※ Case material : Hot-dip galvanized steel board (SGCC)
- ※ Mounting torque : 0.49N · m max
- ※ TB1 screw tightening torque : 1N · m max
- ※ Please connect safety ground to the unit in 2-M3 holes.

Derating Curve

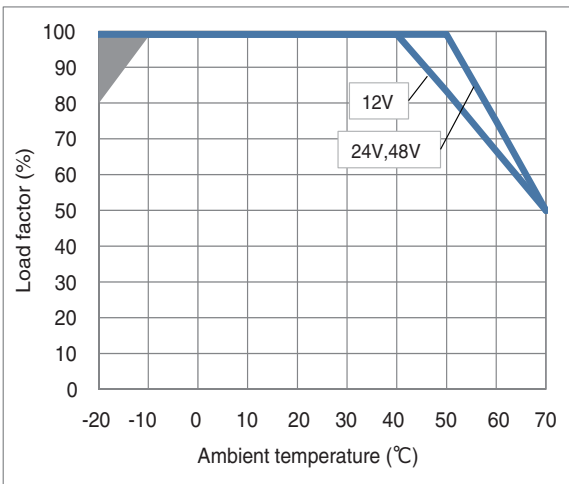

*The shaded area is the derating required at start-up.

Fig.1 Derating curve depending on ambient temperature

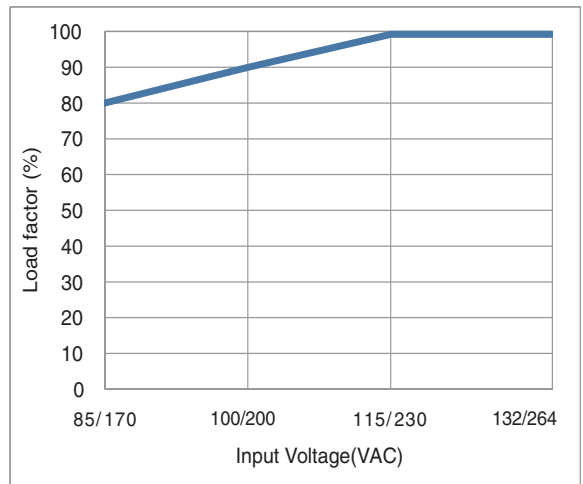

Fig.2 Derating curve depending on input voltage

■ The ambient temperature should be measured 5 to 10 cm away from the power supply so that it won't be influenced by the heat from the power supply. Please consult us for more details.

WMA350H

WM A 350 H -□ -□
 ① ② ③ ④ ⑤ ⑥



- ① Series name
- ② Single output
- ③ Output wattage
- ④ Input voltage selectable by switch
- ⑤ Output voltage
- ⑥ Optional : *5
 C : With Coating
 G : Low leakage current
 T1 : Horizontal terminal block

*Make sure necessary tests will be carried out on your end equipment with the power supply installed in accordance with any required EMC/EMI regulations.

MODEL	WMA350H-12	WMA350H-24	WMA350H-36	WMA350H-48
MAX OUTPUT WATTAGE[W]	348	350.4	349.2	350.4
DC OUTPUT	12V 29A	24V 14.6A	36V 9.7A	48V 7.3A

SPECIFICATIONS

	MODEL	WMA350H-12	WMA350H-24	WMA350H-36	WMA350H-48	
INPUT	VOLTAGE[V]	AC85 - 132 1φ/AC170 - 264 1φ (Selectable by switch)				
	CURRENT[A]	ACIN 115V	6.0			
		ACIN 230V	3.3			
	FREQUENCY[Hz]	50/60 (47-63)				
	EFFICIENCY[%]	ACIN 115V	85typ	87typ	88typ	88typ
		ACIN 230V	86typ	88typ	89typ	89typ
	INRUSH CURRENT[A]	ACIN 115V	60typ Ta=25°C (at cold start)			
ACIN 230V		60typ Ta=25°C (at cold start)				
LEAKAGE CURRENT[mA]	ACIN 115V	0.3max				
	ACIN 240V	0.5max				
OUTPUT	VOLTAGE[V]	12	24	36	48	
	CURRENT[A]	29	14.6	9.7	7.3	
	WATTAGE[W]	348	350.4	349.2	350.4	
	LINE REGULATION[mV] *1	120max	240max	360max	480max	
	LOAD REGULATION[mV] *1	120max	240max	360max	480max	
	RIPPLE NOISE [mVp-p] *2 Io=100%	150max (Bandwidth 20MHz)				
	TEMPERATURE REGULATION[mV] 0~+50°C	180max	360max	540max	720max	
	START-UP TIME[ms]	ACIN 115V	1300typ			
		ACIN 230V	1300typ			
	HOLD-UP TIME[ms]	ACIN 115V	12typ			
		ACIN 230V	16typ			
OUTPUT VOLTAGE ADJUSTMENT RANGE[V]	10.8 to 13.2	21.6 to 26.4	32.4 to 39.6	43.2 to 52.8		
OUTPUT VOLTAGE SETTING[V]	11.75 to 12.25	23.5 to 24.5	35.0 to 37.0	47.0 to 49.0		
PROTECTION CIRCUIT AND OTHERS	OVERCURRENT PROTECTION [A]	Works over 105% of rating and recovers automatically				
	OVERVOLTAGE PROTECTION[V]	13.8 to 16.8	27.6 to 33.6	41.4 to 50.4	55.2 to 67.2	
	OPERATING INDICATION	LED (Green)				
ISOLATION	INPUT-OUTPUT	AC4,000V 1minute, Cutoff current = 10mA, DC500V 50MΩ min (At Room Temperature) 2MOPP				
	INPUT-FG	AC2,000V 1minute, Cutoff current = 10mA, DC500V 50MΩ min (At Room Temperature) 1MOPP				
	OUTPUT-FG	AC500V 1minute, Cutoff current = 100mA, DC500V 50MΩ min (At Room Temperature)				
ENVIRONMENT	OPERATING TEMP.,HUMID. *3	-20 to +70°C, 20-90%RH (Non condensing)				
	STORAGE TEMP.,HUMID.	-20 to +75°C, 20-90%RH (Non condensing)				
	VIBRATION	10 - 55Hz, 19.6m/s ² (2G) , 3minutes period, 60minutes each along X, Y and Z axis				
	IMPACT	196.1m/s ² (20G) , 11ms, once each X, Y and Z axis				
SAFETY AND EMC	AGENCY APPROVALS	UL62368-1, C-UL (equivalent to CAN/CSA-C22.2 No.62368-1), EN62368-1, ANSI/AAMI ES60601-1, C-UL (equivalent to CAN/CSA-C22.2 No.60601-1), EN60601-1 3rd, EN61558-2-16 (OVC III), Complies with IEC60601-1-2 4th Ed.				
	EMC EMISSION	Complies with CISPR11-B, CISPR32-B, EN55011-B, EN55032-B, FCC Part 15-B, FCC Part 18-B				
	EMC IMMUNITY	Complies with EN61000-4-2, 3, 4, 5, 6, 8, 11				
OTHERS	CASE SIZE/WEIGHT	115X30X215mm (W×H×D) / 800g max				
	COOLING METHOD	Forced cooling (internal fan)				
WARRANTY	WARRANTY *4	5 years (subject to the operating conditions)				

*1 Consult us about dynamic load and input response.
 *2 This is the result of measurement of the testing board with capacitors of 47μF and 0.1μF placed at 150 mm from the output terminals by a 20MHz oscilloscope or a ripple-noise meter equivalent to Keisoku-GikenRM104.
 *3 Output power derating is required. Refer to "Derating"
 *4 Consult us about details.
 *5 The listed options may affect the published standard specifications. Please contact us for detailed product specifications and safety approvals.

* All parameters not specially mentioned are measured at ACIN 230V, rated load and 25°C of ambient temperature.
 * Do not use the power supply in overcurrent conditions or in unspecified input voltage ranges. Otherwise the internal components may be damaged.
 * Parallel operation is not possible with this model.
 * Acoustic noise may be heard from the power supply when used for pulse load.

External view

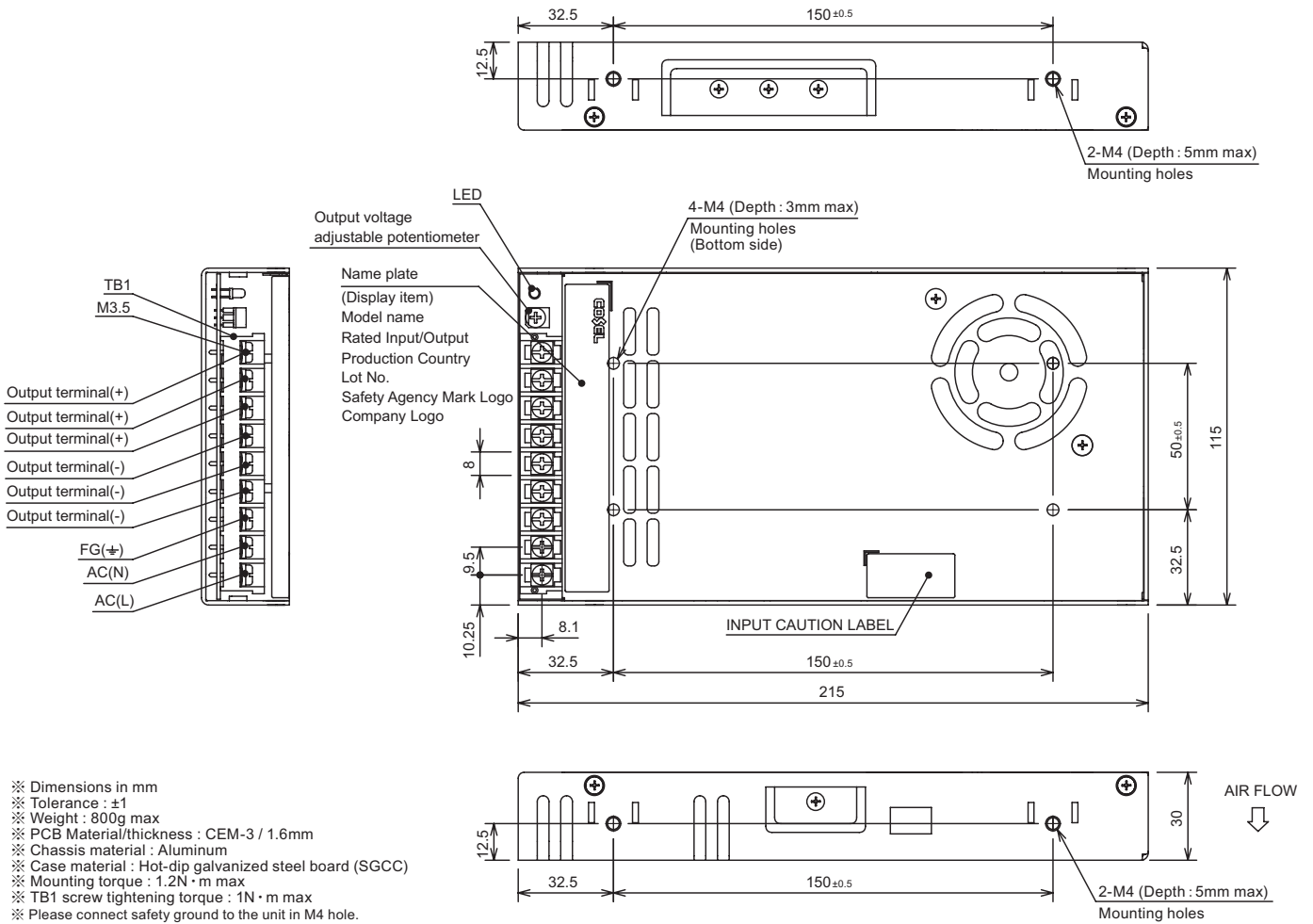

Derating Curve

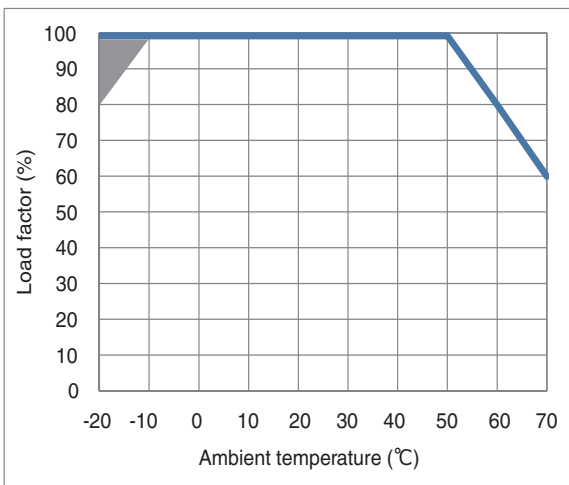

*The shaded area is the derating required at start-up.
Fig.1 Derating curve depending on ambient temperature

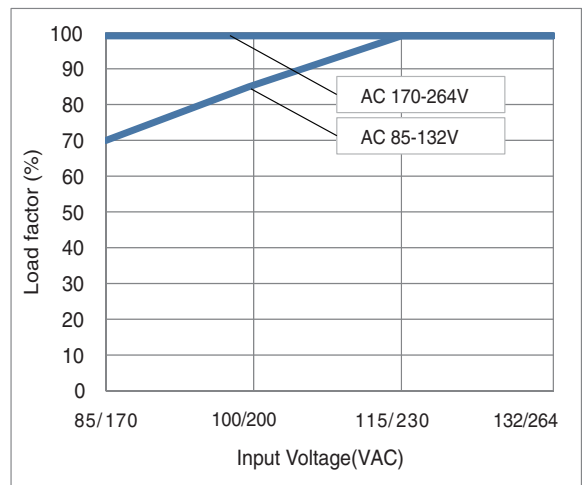
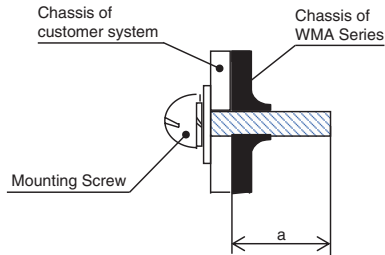

Fig.2 Derating curve depending on input voltage

■ The ambient temperature should be measured 5 to 10 cm away from the power supply so that it won't be influenced by the heat from the power supply. Please consult us for more details.

Assembling and Installation Method

■ To keep enough isolation between screws and internal components, the length of the mounting screw should not exceed recommendation as shown in the figure.



Model	Mounting screw	Mounting hole	a (Max penetration length)
WMA35F WMA75F WMA100F WMA150H	M3	Bottom	3mm max
		Side	5mm max
WMA350H	M4	Bottom	3mm max
		Side	5mm max

■ In order to withstand vibrations and impact, support which is shown in the figure is necessary.

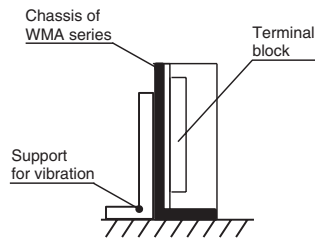

WMA35F WMA75F WMA100F WMA150H

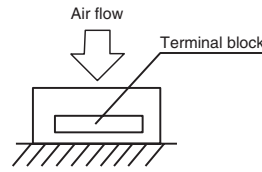

WMA350H

- If you use two or more power supplies side by side, please keep a sufficient distance between them to allow enough air ventilation.
- Ambient temperature around each power supply should not exceed the temperature range shown in the derating curve.
- The unit has cooling fan. (WMA350H)
Ensure that the inlet and outlet vents are not blocked.

Instruction Manual

■ Please read the "Instruction Manual" and "Before using our product" before you use our product.

Basic Characteristics Data

Model	Circuit method	Switching frequency [kHz]	Input current [A]	Rated input fuse	Inrush current protection circuit	PCB/Pattern			Parallel operation
						Material	Single sided	Double sided	
WMA35F	Flyback converter	50 to 120	0.7	250V 2.5A	Thermistor	CEM-3	Yes		No
WMA75F	Flyback converter	50 to 120	1.4	250V 3.15A	Thermistor	CEM-3	Yes		No
WMA100F	Flyback converter	50 to 120	2.0	250V 3.15A	Thermistor	CEM-3	Yes		No
WMA150H	Flyback converter	50 to 120	1.7/3.0	250V 6.3A	Thermistor	CEM-3	Yes		No
WMA350H	Forwrad converter	65	3.3/6.0	250V 10A	Thermistor	CEM-3	Yes		No

Our company network supports you worldwide with offices in Germany, Austria, Switzerland, the UK and the USA. For more information please contact:

FORTEC

GROUP

FORTEC Elektronik AG | Augsburgener Straße 2b | 82110 Germering
+49 89 894450-0
info@fortecag.de | www.fortecag.de

FORTEC

INTEGRATED

FORTEC Integrated GmbH | Augsburgener Straße 2b | 82110 Germering
+49 89 894363-0
info@fortec-integrated.de | www.fortec-integrated.de

FORTEC

POWER

FORTEC Power GmbH | Lise-Meitner-Straße 3 | 64560 Riedstadt
+49 6158 8285-0
weborder@fortec-power.de | www.fortec-power.de

FORTEC

EGYPT

FORTEC Electronic Design and Solution Egypt SMLC | Linx Business Park
Unit B318 | Smart Village | Giza Governorate
info@fortec-integrated.de | www.fortec-integrated.de

Autronic Steuer- und Regeltechnik GmbH | Siemensstraße 17
74343 Sachsenheim
+49 7147 24-0
vertrieb@autronic.de | www.autronic.de

FORTEC

CZECH REPUBLIC

FORTEC Czech Republic s.r.o. | Přátelství 275 | 330 02 Dýšina
+49 89 894363-0
info@fortec.cz | www.fortec.cz

FORTEC

UNITED STATES

FORTEC United States, Corp. | 87 Raynor Avenue Unit 1 | Ronkonkoma
NY | 11779 | +1 631 5804360
info@fortec.us | www.fortec.us

FORTEC

SWITZERLAND

FORTEC Switzerland AG | Bahnhofstraße 3 | 5436 Würenlos
+41 44 7446111
info@fortec.ch | www.fortec.ch

FORTEC

UNITED KINGDOM

FORTEC Technology UK Ltd. | Osprey House | 1 Osprey Court
Hinchingsbrooke Business Park | Huntingdon | Cambridgeshire | PE29 6FN
+44 1480 411600
info@fortec.uk | www.fortec.uk