

Datasheet

UMA_series

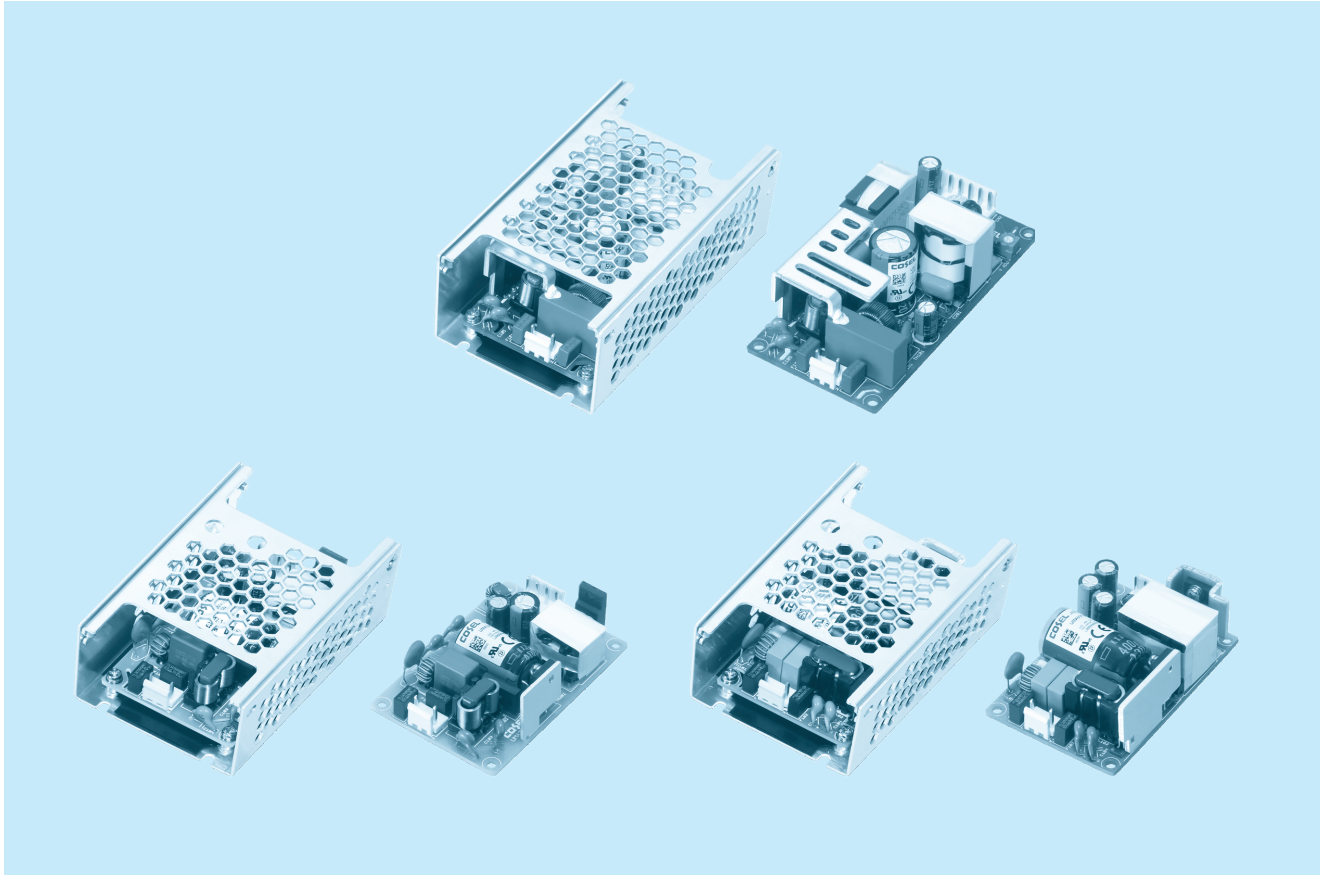

UMA-series



Feature

For medical electric equipment
 Medical Isolation Grade 2MOPP
 4kV isolation
 Suitable for BF application
 Low leakage current
 Power factor correction (UMA120F)
 UMA30F, UMA60F : 2" × 3" standard footprint
 UMA120F : 2" × 4" standard footprint
 Economical design

Safety agency approvals

ANSI/AAMI ES60601-1, EN60601-1 3rd,
 C-UL (CAN/CSA-C22.2 No.60601-1),
 UL62368-1, EN62368-1,
 C-UL (CAN/CSA-C22.2 No.62368-1),
 Complies with IEC60335-1

CE marking

Low Voltage Directive
 RoHS Directive

UKCA marking

Electrical Equipment Safety Regulations
 RoHS Regulations

5-year warranty (See Instruction Manual)

EMI

Complies with CISPR11-B, CISPR32-B, EN55011-B,
 EN55032-B, FCC Part 15-B, FCC Part 18-B

EMS Compliance : EN61204-3, EN61000-6-2 IEC60601-1-2 (2014), EN60601-1-2 (2015)

EN61000-4-2
 EN61000-4-3
 EN61000-4-4
 EN61000-4-5
 EN61000-4-6
 EN61000-4-8
 EN61000-4-11

UMA30F

① **UM** ② **A** ③ **30** ④ **F** ⑤ **-□** ⑥ **-□**

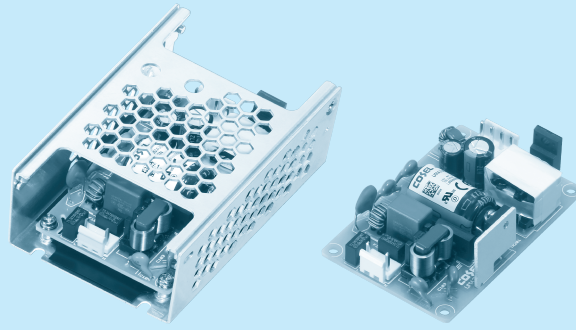

- ① Series name
- ② Single output
- ③ Output wattage
- ④ Universal input
- ⑤ Output voltage
- ⑥ Optional *7
E : IEC Class II
T : Terminal block
SN : with Chassis & cover
Y : with Potentiometer
C : with Coating

*Make sure necessary tests will be carried out on your end equipment with the power supply installed in accordance with any required EMC/EMI regulations.

MODEL	UMA30F-5	UMA30F-12	UMA30F-15	UMA30F-24	UMA30F-36	UMA30F-48
MAX OUTPUT WATTAGE[W]	15	30	30	31.2	30.6	31.2
DC OUTPUT	5V 3A	12V 2.5A	15V 2A	24V 1.3A	36V 0.85A	48V 0.65A

SPECIFICATIONS

	MODEL	UMA30F-5	UMA30F-12	UMA30F-15	UMA30F-24	UMA30F-36	UMA30F-48	
INPUT	VOLTAGE[V]	AC85 - 264 1φ						
	CURRENT[A]	ACIN 115V	0.35	0.7				
		ACIN 230V	0.15	0.3				
	FREQUENCY[Hz]	50/60 (47-63)						
	EFFICIENCY[%]	ACIN 115V	81typ	86typ	86typ	88typ	88typ	88typ
		ACIN 230V	80typ	87typ	87typ	89typ	89typ	89typ
	INRUSH CURRENT[A]	ACIN 115V	25typ					
		ACIN 230V	50typ					
LEAKAGE CURRENT[μA]	ACIN 264V	200max						
TOUCH CURRENT[μA]	ACIN 264V	75max						
OUTPUT	VOLTAGE[V]	5	12	15	24	36	48	
	CURRENT[A]	3	2.5	2	1.3	0.85	0.65	
	WATTAGE[W]	15	30	30	31.2	30.6	31.2	
	LINE REGULATION[mV] *1	20max	48max	60max	96max	144max	192max	
	LOAD REGULATION[mV] *1	100max	120max	120max	150max	240max	240max	
	RIPPLE NOISE [mVp-p] *2 lo=100%	150 (Bandwidth 20MHz)						
	TEMPERATURE REGULATION[mV]	0~+50°C	100max	120max	150max	240max	360max	480max
	START-UP TIME[ms]	ACIN 115V	40typ					
		ACIN 230V	40typ					
	HOLD-UP TIME[ms]	ACIN 115V	20typ					
		ACIN 230V	100typ					
	OUTPUT VOLTAGE ADJUSTMENT RANGE[V]	Fixed ("Y"option is available for adjusting output voltage between ±10%)						
	OUTPUT VOLTAGE SETTING[V]		4.90 to 5.30	11.50 to 12.50	14.40 to 15.60	23.00 to 25.00	34.50 to 37.50	46.00 to 50.00
PROTECTION CIRCUIT AND OTHERS	OVERCURRENT PROTECTION [A]	Works over 105% of rating and recovers automatically						
	OVERVOLTAGE PROTECTION[V]	5.75 to 7.00	13.80 to 16.80	17.25 to 21.00	27.60 to 33.60	41.40 to 50.40	55.20 to 67.20	
ISOLATION	INPUT-OUTPUT	AC4,000V 1minute, DC500V 100MΩ min (At Room Temperature) 2MOPP						
	INPUT-FG	AC2,000V 1minute, DC500V 100MΩ min (At Room Temperature) 1MOPP						
	OUTPUT-FG	AC2,000V 1minute, DC500V 100MΩ min (At Room Temperature) 1MOPP						
ENVIRONMENT	OPERATING TEMP., HUMID. *3	-20 to +70°C, 20 - 90%RH (Non condensing)						
	STORAGE TEMP., HUMID.	-20 to +75°C, 20 - 90%RH (Non condensing)						
	VIBRATION	10 - 55Hz, 19.6m/s ² (2G) , 3minutes period, 60minutes each along X, Y and Z axis						
	IMPACT	196.1m/s ² (20G) , 11ms, once each X, Y and Z axis						
SAFETY AND EMC	AGENCY APPROVALS	ANSI/AAMI ES60601-1, EN60601-1 3rd, C-UL (equivalent to CAN/CSA-C22.2 No.60601-1) , UL62368-1, EN62368-1, C-UL (equivalent to CAN/CSA-C22.2 No.62368-1) , Complies with IEC60335-1						
	EMC EMISSION	Complies with CISPR11-B, CISPR32-B, EN55011-B, EN55032-B, FCC Part 15-B, FCC Part 18-B						
	EMC IMMUNITY	Complies with EN61000-4-2, 3, 4, 5, 6, 8, 11						
	HARMONIC ATTENUATOR*4	Complies with IEC61000-3-2 (Class A) No built-in active PFC						
OTHERS	CASE SIZE/WEIGHT *5	50.8×21.7×76.2mm [2.0×0.85×3.0 inches] (W×H×D) / 80g max (with Chassis and cover : 130g max)						
	COOLING METHOD	Convection						
WARRANTY	WARRANTY *6	5 years (subject to the operating conditions)						

*1 Consult us about dynamic load and input response. Measure the output voltage by using the average mode of the tester to deal with the burst operation at low (lo=0~20%typ) load.

*2 This is the result of measurement of the testing board with capacitors of 47μF and 0.1μF placed at 150 mm from the output terminals by a 20MHz oscilloscope or a ripple-noise meter equivalent to Keisoku-GikenRM104.

When the load factor is low (lo=0~20%typ), the switching power loss is reduced by burst operation, which will cause ripple noise to go beyond the specifications.

*3 Output power derating is required. Refer to "Derating"

*4 Please contact us about another class. When two or more units are operating it may not comply with the IEC61000-3-2. Please contact us for details.

*5 Dimensions below PCB are not included.

*6 Consult us about details.

*7 The listed options may affect the published standard specifications. Please contact us for detailed product specifications and safety approvals.

* All parameters not specially mentioned are measured at ACIN 230V, rated load and 25°C of ambient temperature.

* Do not use the power supply in overcurrent conditions or in unspecified input voltage ranges. Otherwise the internal components may be damaged.

* Parallel operation is not possible with this model.

* Acoustic noise may be heard from the power supply when used for pulse load.

Block diagram

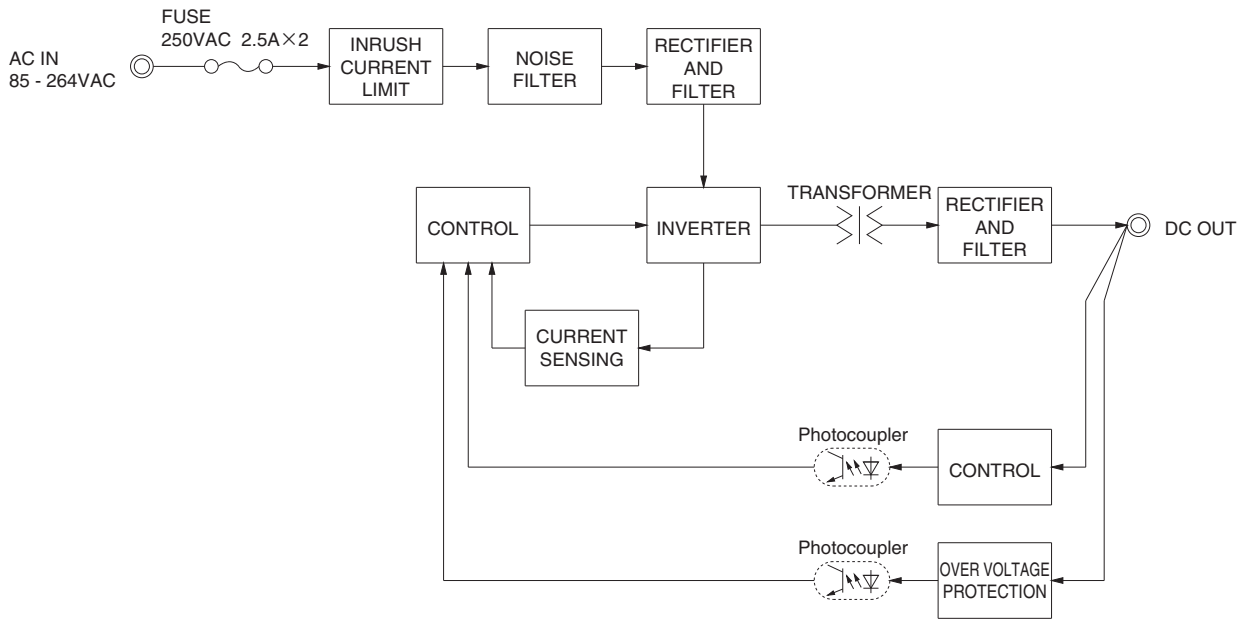

External view

Standard type

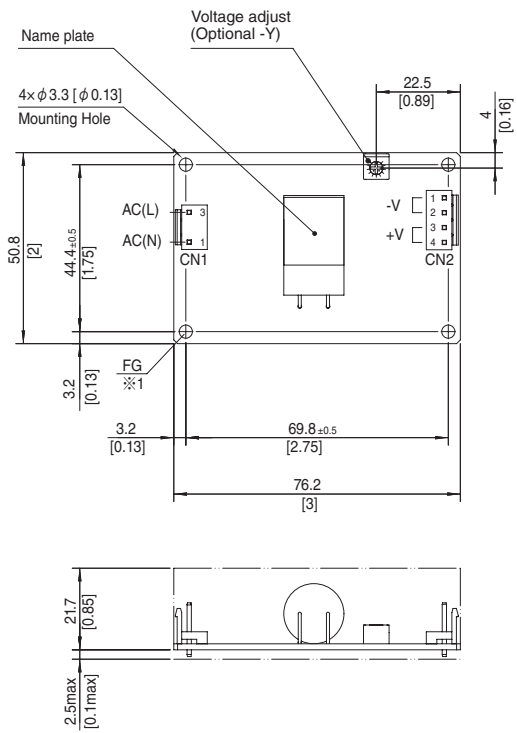

Chassis and cover type

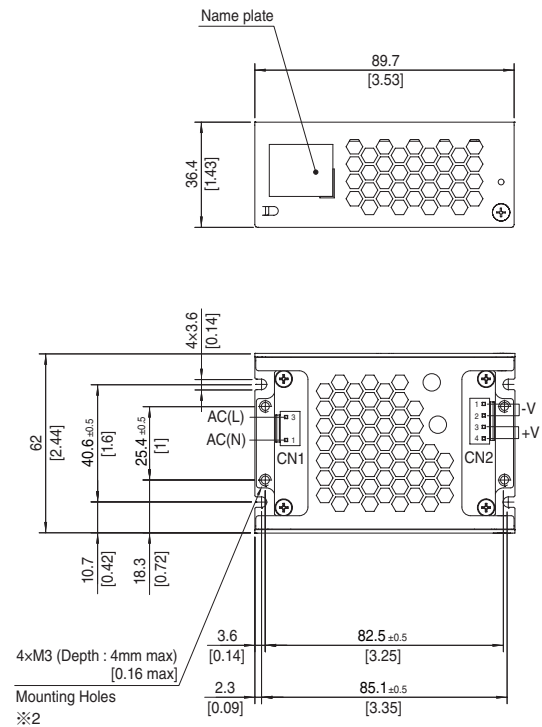

Mating connector and terminal of CN1, CN2

I/O Connector	Mating Connector	Terminal	Mfr.
CN1	B2P3-VH	VHR-3N Reel : SVH-21T-P1.1 Loose piece : BVH-21T-P1.1	J.S.T.
CN2	B4P-VH	VHR-4N Chain : SVH-21T-P1.1 Loose piece : BVH-21T-P1.1	J.S.T.

<Pin Assignments>

CN1		CN2	
Pin No.	Input	Pin No.	Output
1	AC(N)	1, 2	-V
2		3, 4	+V
3	AC(L)		

※ Dimensions in mm, [] =inches

※ Tolerance : ±1 [±0.04]

※ Weight : 80g max (with Chassis and cover 130g max)

※ PCB Material/thickness : CEM-3/1.6 [0.06]

※1 The mounting hole is for FG connection.

The mounting hole in the -E option is not for FG connection.

※2 Mounting torque : 0.49N·m max

UMA60F

① **UM** ② **A** ③ **60** ④ **F** ⑤ **-□** ⑥ **-□**

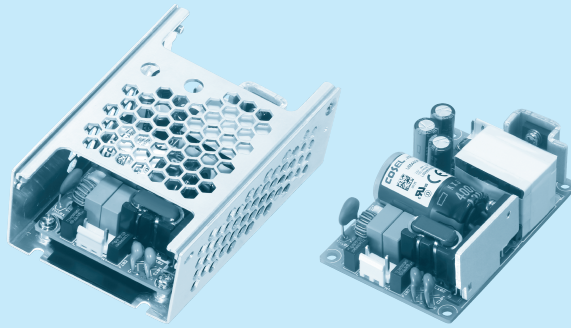

- ① Series name
- ② Single output
- ③ Output wattage
- ④ Universal input
- ⑤ Output voltage
- ⑥ Optional *7
E : IEC Class II
T : Terminal block
SN : with Chassis & cover
Y : with Potentiometer
C : with Coating

*Make sure necessary tests will be carried out on your end equipment with the power supply installed in accordance with any required EMC/EMI regulations.

MODEL	UMA60F-5	UMA60F-7R5	UMA60F-12	UMA60F-15	UMA60F-24	UMA60F-36	UMA60F-48
MAX OUTPUT WATTAGE[W]	30	41.25	54	52.5	60	61.2	60
DC OUTPUT	5V 6A	7.5V 5.5A	12V 4.5A	15V 3.5A	24V 2.5A	36V 1.7A	48V 1.25A

SPECIFICATIONS

	MODEL	UMA60F-5	UMA60F-7R5	UMA60F-12	UMA60F-15	UMA60F-24	UMA60F-36	UMA60F-48	
INPUT	VOLTAGE[V]	AC85 - 264 1φ							
	CURRENT[A]	ACIN 115V	0.7	1.0	1.4				
		ACIN 230V	0.3	0.5	0.7				
	FREQUENCY[Hz]	50/60 (47-63)							
	EFFICIENCY[%]	ACIN 115V	80typ	84typ	87typ	86typ	88typ	89typ	89typ
		ACIN 230V	80typ	85typ	88typ	87typ	90typ	91typ	91typ
	INRUSH CURRENT[A]	ACIN 115V	25typ						
		ACIN 230V	50typ						
LEAKAGE CURRENT[μA]	ACIN 264V	200max							
TOUCH CURRENT[μA]	ACIN 264V	75max							
OUTPUT	VOLTAGE[V]	5	7.5	12	15	24	36	48	
	CURRENT[A]	6	5.5	4.5	3.5	2.5	1.7	1.25	
	WATTAGE[W]	30	41.25	54	52.5	60	61.2	60	
	LINE REGULATION[mV] *1	20max	36max	48max	60max	96max	144max	192max	
	LOAD REGULATION[mV] *1	100max	120max	120max	120max	150max	240max	240max	
	RIPPLE NOISE [mVp-p] *2	Io=100%	150 (Bandwidth 20MHz)						
	TEMPERATURE REGULATION[mV]	0~+50°C	100max	100max	120max	180max	240max	360max	480max
	START-UP TIME[ms]	ACIN 115V	40typ						
		ACIN 230V	40typ						
	HOLD-UP TIME[ms]	ACIN 115V	20typ						
		ACIN 230V	100typ						
OUTPUT VOLTAGE ADJUSTMENT RANGE[V]	Fixed (*Y*option is available for adjusting output voltage between ±10%)								
OUTPUT VOLTAGE SETTING[V]	4.90 to 5.30	7.20 to 7.80	11.50 to 12.50	14.40 to 15.60	23.00 to 25.00	34.50 to 37.50	46.00 to 50.00		
PROTECTION CIRCUIT AND OTHERS	OVERCURRENT PROTECTION [A]	Works over 105% of rating and recovers automatically							
	OVERVOLTAGE PROTECTION[V]	5.75 to 7.00	8.63 to 10.50	13.80 to 16.80	17.25 to 21.00	27.60 to 33.60	41.40 to 50.40	55.20 to 67.20	
ISOLATION	INPUT-OUTPUT	AC4,000V 1minute, DC500V 100MΩ min (At Room Temperature) 2MOPP							
	INPUT-FG	AC2,000V 1minute, DC500V 100MΩ min (At Room Temperature) 1MOPP							
	OUTPUT-FG	AC2,000V 1minute, DC500V 100MΩ min (At Room Temperature) 1MOPP							
ENVIRONMENT	OPERATING TEMP., HUMID. *3	-20 to +70°C, 20 - 90%RH (Non condensing)							
	STORAGE TEMP., HUMID.	-20 to +75°C, 20 - 90%RH (Non condensing)							
	VIBRATION	10 - 55Hz, 19.6m/s ² (2G) , 3minutes period, 60minutes each along X, Y and Z axis							
	IMPACT	196.1m/s ² (20G) , 11ms, once each X, Y and Z axis							
SAFETY AND EMC	AGENCY APPROVALS	ANSI/AAMI ES60601-1, EN60601-1 3rd, C-UL (equivalent to CAN/CSA-C22.2 No.60601-1) , UL62368-1, EN62368-1, C-UL (equivalent to CAN/CSA-C22.2 No.62368-1) , Complies with IEC60335-1							
	EMC EMISSION	Complies with CISPR11-B, CISPR32-B, EN55011-B, EN55032-B, FCC Part 15-B, FCC Part 18-B							
	EMC IMMUNITY	Complies with EN61000-4-2, 3, 4, 5, 6, 8, 11							
	HARMONIC ATTENUATOR*4	Complies with IEC61000-3-2 (Class A) No built-in active PFC							
OTHERS	CASE SIZE/WEIGHT *5	50.8×24.2×76.2mm [2.0×0.95×3.0 inches] (WXHXD) / 120g max (with Chassis and cover : 180g max)							
	COOLING METHOD	Convection							
WARRANTY	WARRANTY *6	5 years (subject to the operating conditions)							

*1 Consult us about dynamic load and input response. Measure the output voltage by using the average mode of the tester to deal with the burst operation at low (Io=0~20%typ) load.
 *2 This is the result of measurement of the testing board with capacitors of 47μF and 0.1μF placed at 150 mm from the output terminals by a 20MHz oscilloscope or a ripple-noise meter equivalent to Keisoku-GikenRM104.
 When the load factor is low (Io=0~20%typ), the switching power loss is reduced by burst operation, which will cause ripple noise to go beyond the specifications.
 *3 Output power derating is required. Refer to "Derating"
 *4 Please contact us about another class. When two or more units are operating it may not comply with the IEC61000-3-2. Please contact us for details.

*5 Dimensions below PCB are not included.
 *6 Consult us about details.
 *7 The listed options may affect the published standard specifications. Please contact us for detailed product specifications and safety approvals.
 * All parameters not specially mentioned are measured at ACIN 230V, rated load and 25°C of ambient temperature.
 * Do not use the power supply in overcurrent conditions or in unspecified input voltage ranges. Otherwise the internal components may be damaged.
 * Parallel operation is not possible with this model.
 * Acoustic noise may be heard from the power supply when used for pulse load.

Block diagram

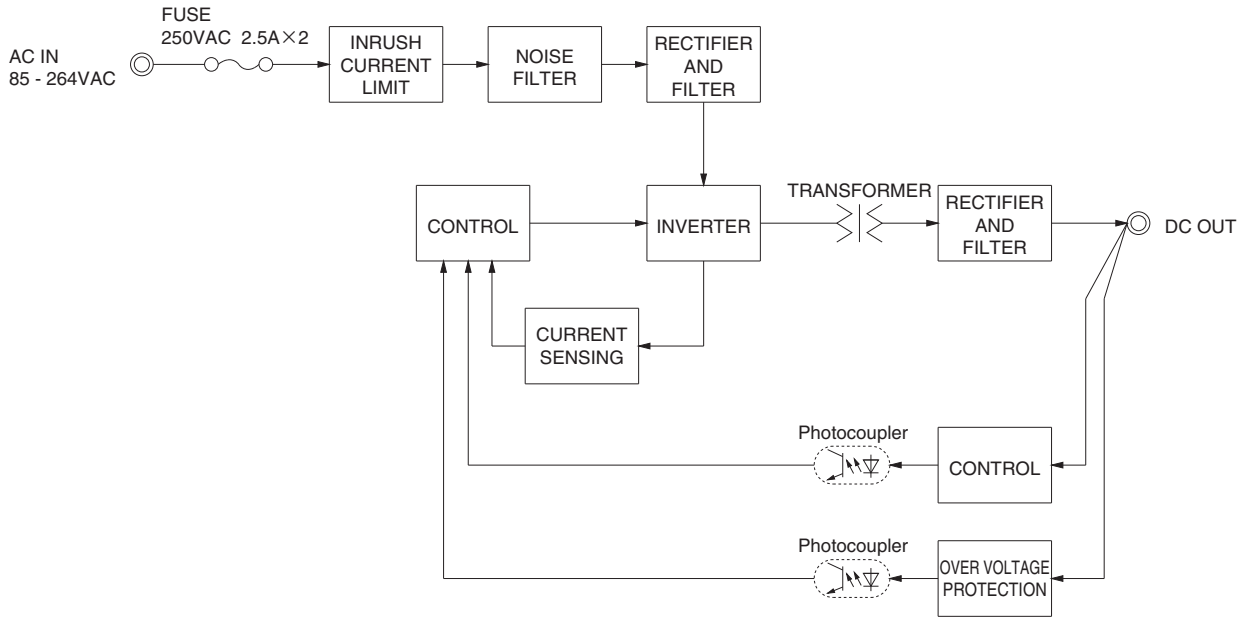

External view

Standard type

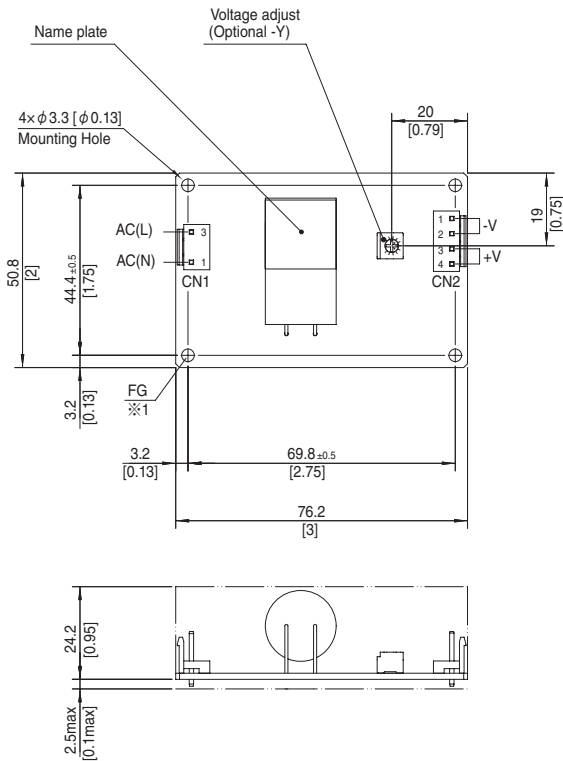

Chassis and cover type

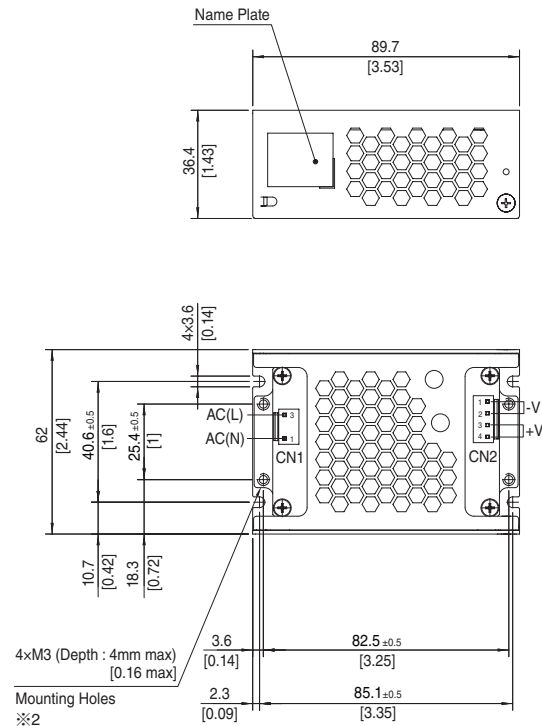

Mating connector and terminal of CN1, CN2

I/O Connector	Mating Connector	Terminal	Mfr.
CN1	B2P3-VH	VHR-3N Reel : SVH-21T-P1.1 Loose piece : BVH-21T-P1.1	J.S.T.
CN2	B4P-VH	VHR-4N Chain : SVH-21T-P1.1 Loose piece : BVH-21T-P1.1	J.S.T.

<Pin Assignments>

CN1		CN2	
Pin No.	Input	Pin No.	Output
1	AC(N)	1, 2	-V
2		3, 4	+V
3	AC(L)		

※ Dimensions in mm, [] =inches

※ Tolerance : ±1 [±0.04]

※ Weight : 120g max (with Chassis and cover 180g max)

※ PCB Material/thickness : FR-4/1.6 [0.06]

※1 The mounting hole is for FG connection.

The mounting hole in the -E option is not for FG connection.

※2 Mounting torque : 0.49N·m max

UMA120F

① **UM** ② **A** ③ **120** ④ **F** ⑤ **-□** ⑥ **-□**

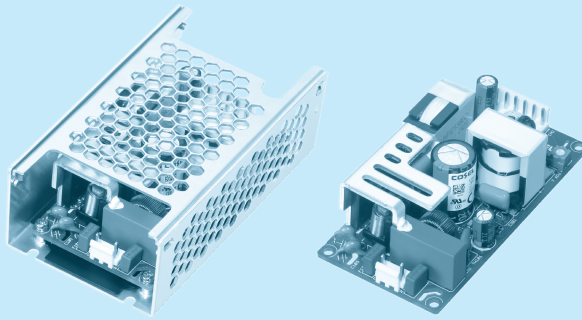

- ① Series name
- ② Single output
- ③ Output wattage
- ④ Universal input
- ⑤ Output voltage
- ⑥ Optional *7
T : Terminal block
SN: with Chassis & cover
C: with Coating

* Make sure necessary tests will be carried out on your end equipment with the power supply installed in accordance with any required EMC/EMI regulations.

MODEL	UMA120F-5-Y	UMA120F-7R5-Y	UMA120F-12-Y	UMA120F-15-Y	UMA120F-18-Y	UMA120F-24-Y	UMA120F-36-Y	UMA120F-48-Y
MAX OUTPUT WATTAGE[W]	60	90	120	97.5	108	120	108	120
DC OUTPUT	5V 12A	7.5V 12A	12V 10A	15V 6.5A	18V 6A	24V 5A	36V 3A	48V 2.5A

SPECIFICATIONS

	MODEL	UMA120F-5-Y	UMA120F-7R5-Y	UMA120F-12-Y	UMA120F-15-Y	UMA120F-18-Y	UMA120F-24-Y	UMA120F-36-Y	UMA120F-48-Y	
INPUT	VOLTAGE[V]	AC85 - 264 1φ								
	CURRENT[A]	ACIN 115V	0.7	0.9	1.2	1.0	1.1	1.2	1.1	1.2
		ACIN 230V	0.4	0.5	0.6	0.5	0.6	0.6	0.6	0.6
	FREQUENCY[Hz]	50/60(47-63)								
	EFFICIENCY[%]	ACIN 115V	87typ	90typ	91typ	91typ	91typ	92typ	91typ	92typ
		ACIN 230V	89typ	92typ	93typ	93typ	93typ	94typ	93typ	94typ
	INRUSH CURRENT[A]	ACIN 115V	25typ							
		ACIN 230V	50typ							
	POWR FACTOR	ACIN 115V	0.98	0.98	0.98	0.98	0.98	0.98	0.98	0.98
		ACIN 230V	0.85	0.90	0.93	0.91	0.92	0.93	0.92	0.93
LEAKAGE CURRENT[uA]	ACIN 264V	200max								
TOUCH CURRENT[uA]	ACIN 264V	75max								
OUTPUT	VOLTAGE[V]	5	7.5	12	15	18	24	36	48	
	CURRENT[A]	12	12	10	6.5	6	5	3	2.5	
	WATTAGE[W]	60	90	120	97.5	108	120	108	120	
	LINE REGULATION[mV] *1	20max	36max	48max	60max	72max	96max	114max	192max	
	LOAD REGULATION[mV] *1	100max	100max	100max	120max	150max	150max	240max	240max	
	RIPPLE NOISE [mVp-p] *2 lo=100%	150 (Bandwidth 20MHz)								
	TEMPERATURE REGULATION [mV]	0~+50°C	100max	100max	120max	150max	180max	240max	360max	480max
	START-UP TIME[ms]	ACIN 115V	700typ							
		ACIN 230V	700typ							
	HOLD-UP TIME[ms]	16typ								
	OUTPUT VOLTAGE ADJUSTMENT RANGE[V]	4.75 to 5.25	7.12 to 7.88	11.40 to 12.60	14.25 to 15.75	18.00 to 19.80	22.80 to 25.20	34.20 to 37.80	45.60 to 50.40	
	OUTPUT VOLTAGE SETTING[V]	5.00 to 5.13	7.50 to 7.69	12.00 to 12.30	15.00 to 15.38	18.00 to 18.45	24.00 to 24.60	36.00 to 36.90	48.00 to 49.20	
PROTECTION CIRCUIT AND OTHERS	OVERCURRENT PROTECTION [A]	Works over 105% of rating and recovers automatically								
	OVERVOLTAGE PROTECTION[V]	5.75 to 7.00	8.63 to 10.50	13.80 to 16.80	17.25 to 21.00	20.70 to 25.20	27.60 to 33.60	41.40 to 50.40	55.20 to 67.20	
ISOLATION	INPUT-OUTPUT	AC4,000V 1minute, DC500V 100MΩ min (At Room Temperature) 2MOPP								
	INPUT-FG	AC2,000V 1minute, DC500V 100MΩ min (At Room Temperature) 1MOPP								
	OUTPUT-FG	AC2,000V 1minute, DC500V 100MΩ min (At Room Temperature) 1MOPP								
ENVIRONMENT	OPERATING TEMP., HUMID. *3	-20 to +70°C, 20 - 90%RH (Non condensing)								
	STORAGE TEMP., HUMID.	-20 to +75°C, 20 - 90%RH (Non condensing)								
	VIBRATION	10 - 55Hz, 19.6m/s ² (2G) , 3minutes period, 60minutes each along X, Y and Z axis								
	IMPACT	196.1m/s ² (20G) , 11ms, once each X, Y and Z axis								
SAFETY AND EMC	AGENCY APPROVALS	ANSI/AAMI ES60601-1, EN60601-1 3rd, C-UL (equivalent to CAN/CSA-C22.2 No.60601-1), UL62368-1, EN62368-1, C-UL (equivalent to CAN/CSA-C22.2 No.62368-1)								
	EMC EMISSION	Complies with CISPR11-B, CISPR32-B, EN55011-B, EN55032-B, FCC Part15-B and FCC Part18-B								
	EMC IMMUNITY	Complies with EN61000-4-2, 3, 4, 5, 6, 8, 11								
	HARMONIC ATTENUATOR*4	Complies with IEC61000-3-2 Class A								
OTHERS	CASE SIZE/WEIGHT *5	50.8×29.0×101.6mm [2.0×1.14×4.0 inches] (WXHXD) / 150g max (with Chassis and cover : 250g max)								
	COOLING METHOD	Convection								
WARRANTY	WARRANTY *6	5 years (subject to the operating conditions)								

*1 Consult us about dynamic load and input response. Measure the output voltage by using the average mode of the tester to deal with the burst operation at low (lo=0~10%typ) load.
 *2 This is the result of measurement of the testing board with capacitors of 47μF and 0.1μF placed at 150 mm from the output terminals by a 20MHz oscilloscope or a ripple-noise meter equivalent to Keisoku-GikenRM104.
 When the load factor is low (lo=0~10%typ), the switching power loss is reduced by burst operation, which will cause ripple noise to go beyond the specifications.
 *3 Output power derating is required. Refer to "Derating"
 *4 Please contact us about another class.

*5 Dimensions below PCB are not included.
 *6 Consult us about details.
 *7 The listed options may affect the published standard specifications. Please contact us for detailed product specifications and safety approvals.
 * All parameters not specially mentioned are measured at ACIN 230V, rated load and 25°C of ambient temperature.
 * Do not use the power supply in overcurrent conditions or in unspecified input voltage ranges. Otherwise the internal components may be damaged.
 * Parallel operation is not possible with this model.
 * Acoustic noise may be heard from the power supply when used for pulse load.

Block diagram

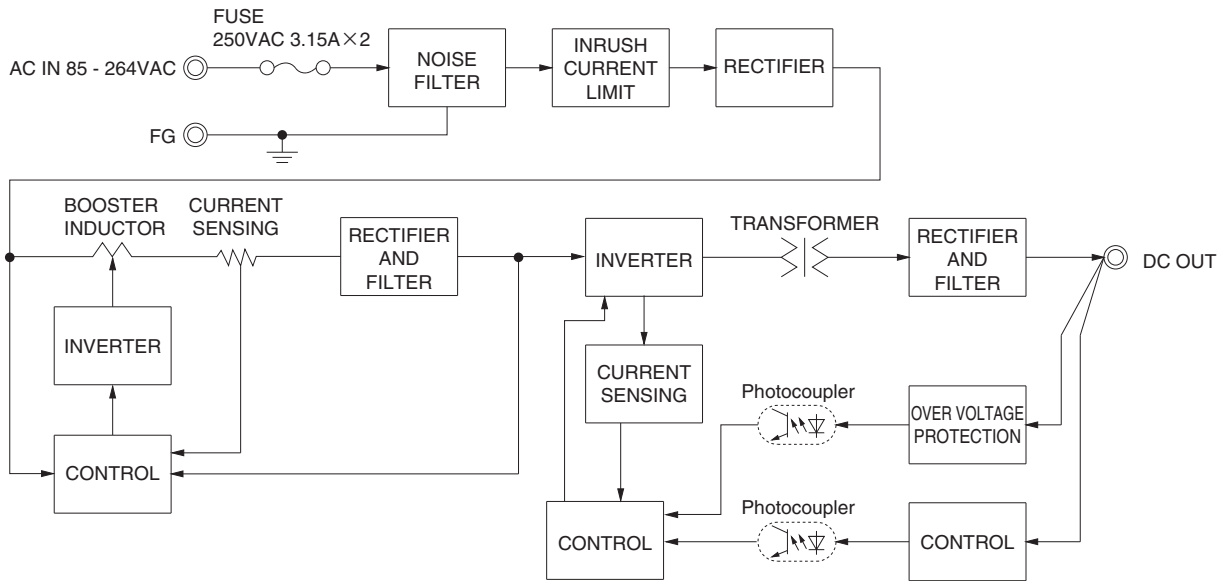

External view

Standard type

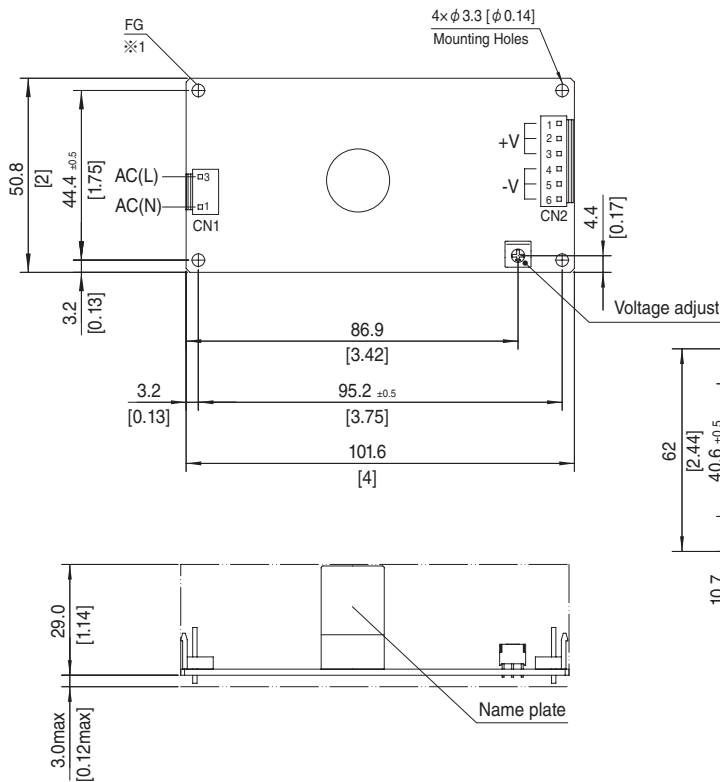

Chassis and cover type

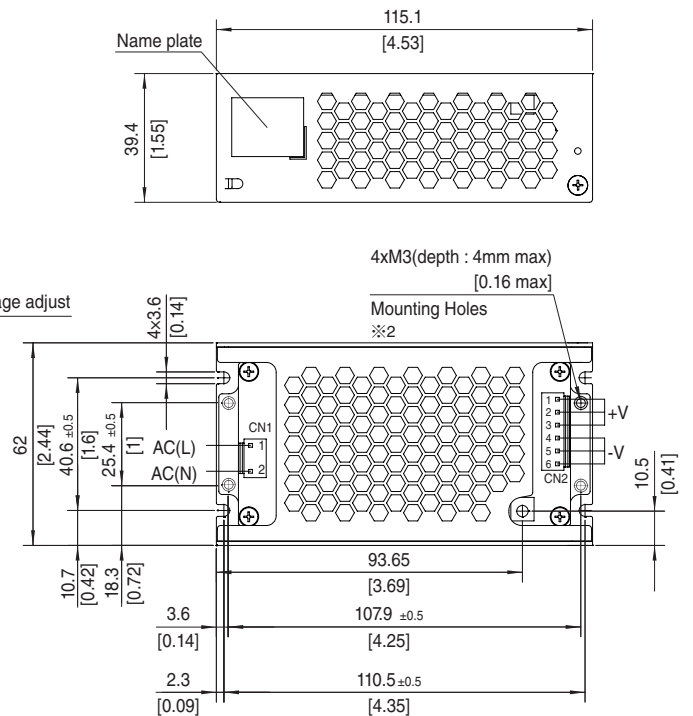

Mating connector and terminal of CN1, CN2

I/O Connector	Mating Connector	Terminal	Mfr.
CN1	B2P3-VH	VHR-3N Reel : SVH-21T-P1.1 Loose piece : BVH-21T-P1.1	J.S.T.
CN2	B6P-VH	VHR-6N Reel : SVH-21T-P1.1 Loose piece : BVH-21T-P1.1	J.S.T.

<Pin Assignments>

CN1		CN2	
Pin No.	Input	Pin No.	Output
1	AC(N)	1, 2, 3	+V
2		4, 5, 6	-V
3	AC(L)		

※ Dimensions in mm, [] =inches

※ Tolerance : ±1 [±0.04]

※ Weight : 150g max (with Chassis and cover 250g max)

※ PCB Material/thickness : FR-4/1.6 [0.06]

※1 The mounting hole is for FG connection.

※2 Mounting torque : 0.49N·m max

Assembling and Installation Method

■ When the power supply is used with natural convection cooling, the standard mounting position is horizontal.

■ AC voltage exists on the primary side. Therefore, in order to prevent electric shock, or to meet the leakage current requirements of the safety standard, you need to ensure the proper insulation distance.

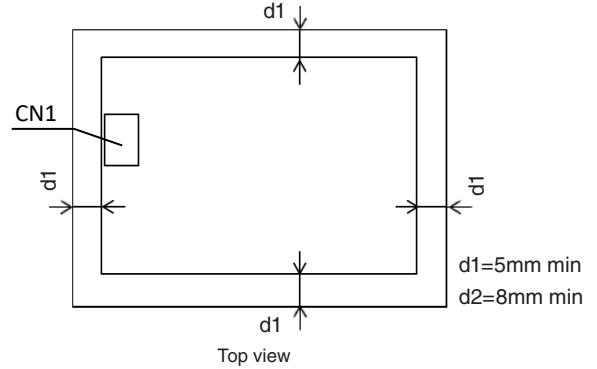
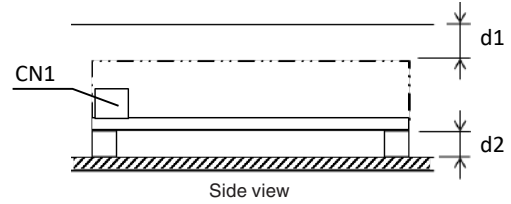

Mounting screw

■ The mounting screws should be M3. The hatched area indicates the proper area for mounting hardware.

● **UMA30F, UMA60F**

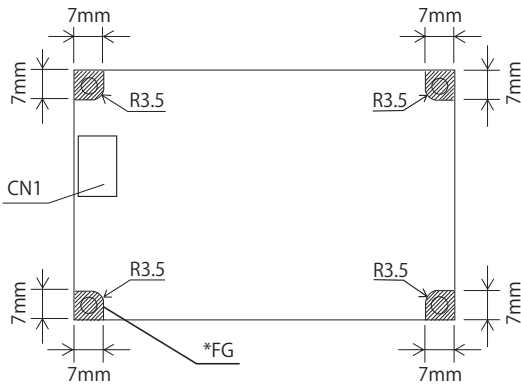

* Recommend to electrically connect FG to metal chassis for reducing noise.

● **UMA120F**

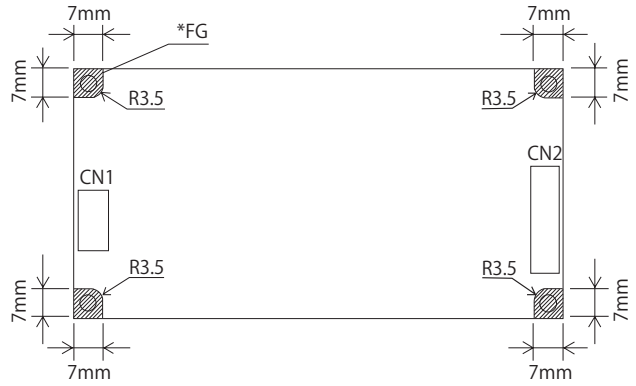

* Recommend to electrically connect FG to metal chassis for reducing noise.

■ The mounting screws should be M3.
The hatched area indicates the proper area for mounting hardware.

■ This power supply is manufactured by SMD technology.
Stress to the PCB such as twisting or bending may cause damage to the unit, please handle with care.

Derating

Derating curve for input voltage

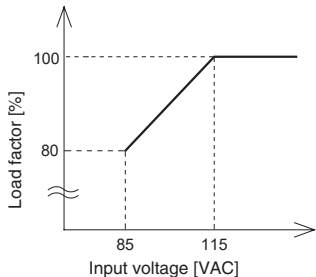

UMA30F Ambient temperature derating curve at rated input

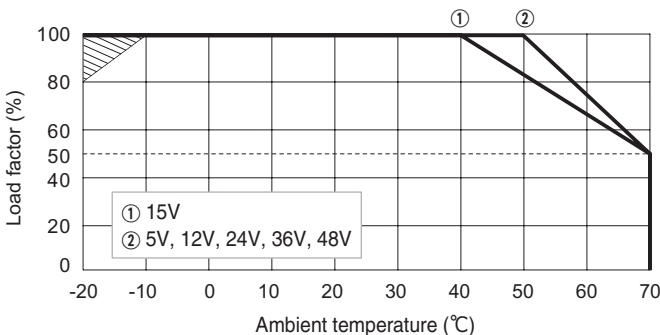

UMA30F-SN Ambient temperature derating curve at rated input

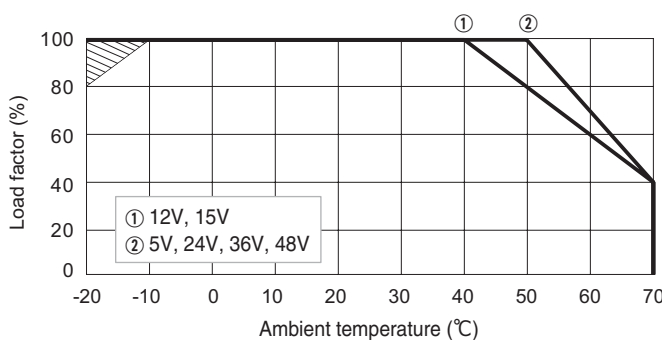

UMA60F Ambient temperature derating curve at rated input

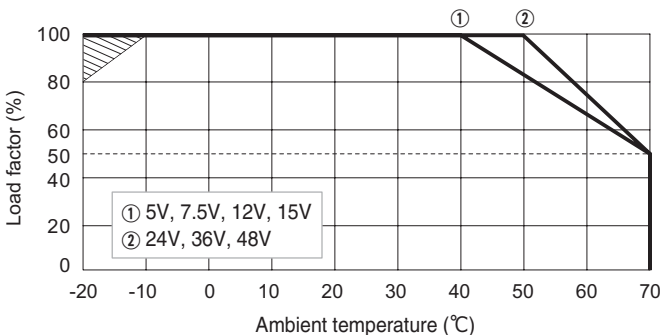

UMA60F-SN Ambient temperature derating curve at rated input

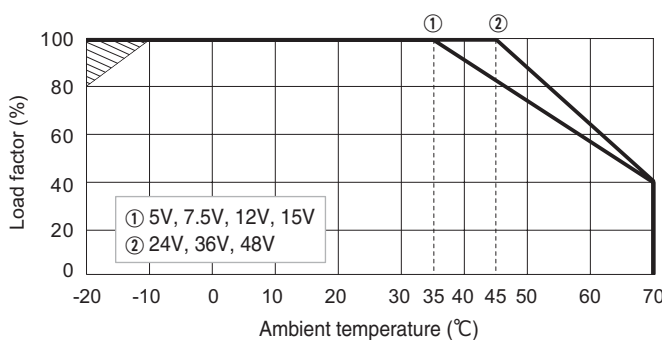

UMA120F Ambient temperature derating curve at rated input

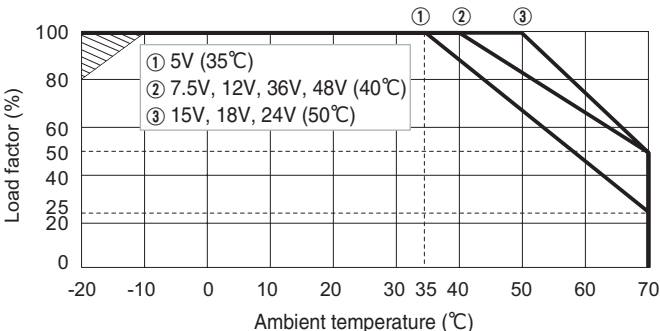

UMA120F-SN Ambient temperature derating curve at rated input

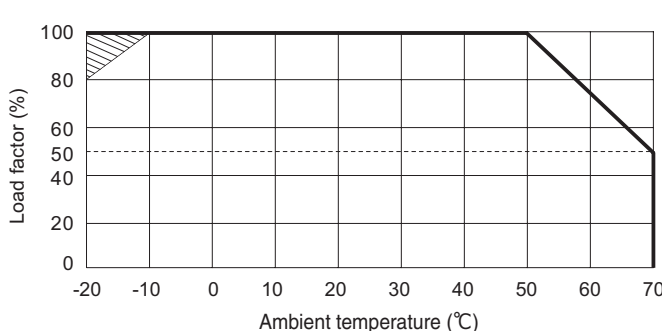

- The ambient temperature should be measured 5 to 10 cm away from the power supply so that it won't be influenced by the heat from the power supply. Please consult us for more details.
- The shaded area is the derating required at start-up.

Instruction Manual

■ Please read the “Instruction Manual” and “Before using our product” before you use our product.

Basic Characteristics Data

Model	Circuit method	Switching frequency [kHz]	Input current [A]	Rated input fuse	Inrush current protection circuit	PCB/Pattern			Parallel operation
						Material	Single sided	Double sided	
UMA30F	Flyback converter	20 to 125	0.7	250V 2.5A	Thermistor	CEM-3	Yes		No
UMA60F	Flyback converter	20 to 125	1.4	250V 2.5A	Thermistor	FR4		Yes	No
UMA120F	Active filter	15 to 300	1.2	250V 3.15A	Thermistor	FR4		Yes	No
	LLC resonant converter	50 to 280							

FORTEC

GROUP

Our company network supports you worldwide with offices in Germany, Austria, Switzerland, the UK and the USA. For more information please contact:

FORTEC

GROUP

FORTEC Elektronik AG | Augsburgener Straße 2b | 82110 Germering
+49 89 894450-0
info@fortecag.de | www.fortecag.de

FORTEC

INTEGRATED

FORTEC Integrated GmbH | Augsburgener Straße 2b | 82110 Germering
+49 89 894363-0
info@fortec-integrated.de | www.fortec-integrated.de

FORTEC

POWER

FORTEC Power GmbH | Lise-Meitner-Straße 3 | 64560 Riedstadt
+49 6158 8285-0
weborder@fortec-power.de | www.fortec-power.de

FORTEC

EGYPT

FORTEC Electronic Design and Solution Egypt SMLC | Linx Business Park
Unit B318 | Smart Village | Giza Governorate
info@fortec-integrated.de | www.fortec-integrated.de

Autronic Steuer- und Regeltechnik GmbH | Siemensstraße 17
74343 Sachsenheim
+49 7147 24-0
vertrieb@autronic.de | www.autronic.de

FORTEC

CZECH REPUBLIC

FORTEC Czech Republic s.r.o. | Přátelství 275 | 330 02 Dýšina
+49 89 894363-0
info@fortec.cz | www.fortec.cz

FORTEC

UNITED STATES

FORTEC United States, Corp. | 87 Raynor Avenue Unit 1 | Ronkonkoma
NY | 11779 | +1 631 5804360
info@fortec.us | www.fortec.us

FORTEC

SWITZERLAND

FORTEC Switzerland AG | Bahnhofstraße 3 | 5436 Würenlos
+41 44 7446111
info@fortec.ch | www.fortec.ch

FORTEC

UNITED KINGDOM

FORTEC Technology UK Ltd. | Osprey House | 1 Osprey Court
Hinchingsbrooke Business Park | Huntingdon | Cambridgeshire | PE29 6FN
+44 1480 411600
info@fortec.uk | www.fortec.uk