

Datasheet

LMA_series

FORTEC
UNITED STATES

FORTEC
INTEGRATED

FORTEC
UNITED KINGDOM

The information contained in this document has been carefully researched and is, to the best of our knowledge, accurate. However, we assume no liability for any product failures or damages, immediate or consequential, resulting from the use of the information provided herein. Our products are not intended for use in systems in which failures of product could result in personal injury. All trademarks mentioned herein are property of their respective owners. All specifications are subject to change without notice.



LMA-series

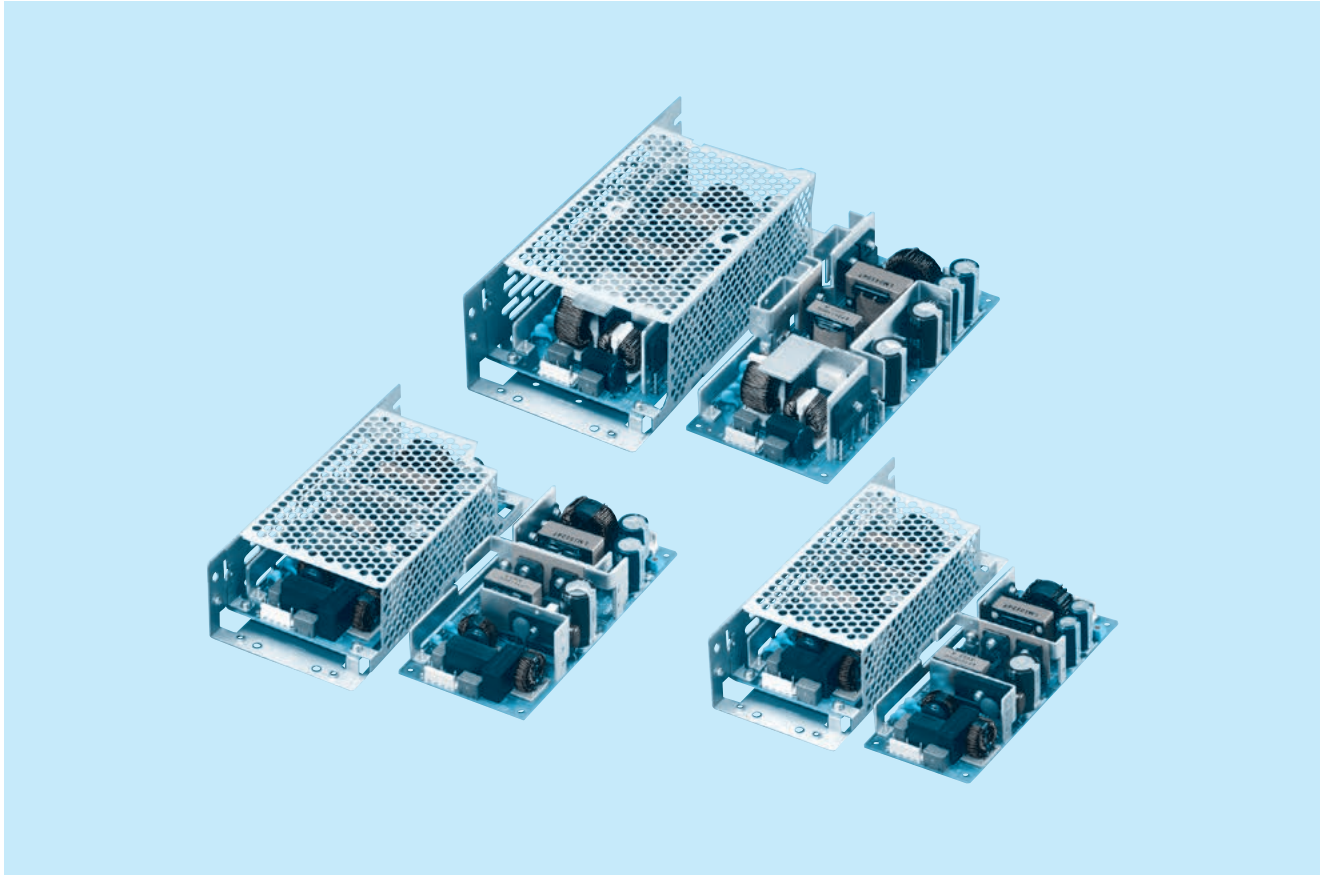

■ Feature

- For medical electric equipment
- Internal dual fuses
- Low leakage current
- High power & peak power (option)
- Small and compact PCB construction
- Built-in inrush current, overcurrent and overvoltage protection circuits
- Harmonic attenuator (Complies with IEC61000-3-2 class A)
- Universal input (AC85-264V)
- Power factor correction

■ Safety agency approvals

ANSI/AAMI ES60601, EN60601-1 3rd

■ EMI

Complies with FCC-B, CISPR22-B, EN55011-B, EN55022-B, VCCI-B

■ 5-year warranty

■ CE marking

Low Voltage Directive
RoHS Directive

■ UKCA marking

Electrical Equipment Safety Regulations
RoHS Regulations

■ EMS Compliance

: EN61204-3, EN61000-6-2
IEC60601-1-2 (2014), EN60601-1-2 (2015)

- EN61000-4-2
- EN61000-4-3
- EN61000-4-4
- EN61000-4-5
- EN61000-4-6
- EN61000-4-8
- EN61000-4-11

LMA100F

LM A 100 F -□ -□

① ② ③ ④ ⑤ ⑥

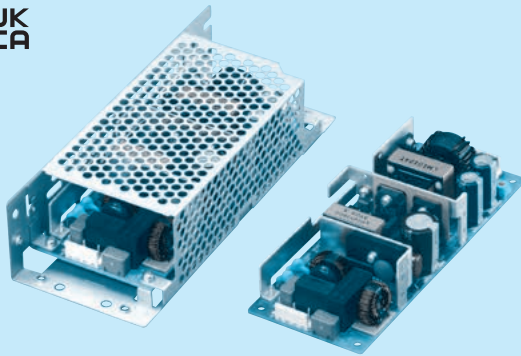

Example recommended EMI/EMC filter
NAM-04-101



High voltage pulse noise type : NAP series
Low leakage current type : NAM series
* A higher current rating EMI/EMC filter may be recommended in view of the other devices that could be connected in parallel with the power supply.

- ① Series name
- ② Single output
- ③ Output wattage
- ④ Universal input
- ⑤ Output voltage
- ⑥ Optional *1
- C : with Coating
- G : Low leakage current
- H : with the function to be acceptable to output peak current
- J1 : VH(J.S.T.)connector type
- R : with Remote ON/OFF
- R2 : with Remote ON/OFF
- S : with Chassis
- SN : with Chassis & cover
- P : Setting in the overcurrent protection rating

This power supply is manufactured by SMD technology. The stress to P.C.B like twisting or bending causes the defect of the unit, so handle the unit with care.
*Make sure necessary tests will be carried out on your end equipment with the power supply installed in accordance with any required EMC/EMI regulations.

MODEL	LMA100F-24-Y	LMA100F-24-HY
MAX OUTPUT WATTAGE[W]	103.2	103.2 (206.4) *2
DC OUTPUT	24V 4.3A	24V 4.3A (8.6A) *2

SPECIFICATIONS

	MODEL	LMA100F-24-Y	LMA100F-24-HY	
INPUT	VOLTAGE[V]	AC85 - 264 1 φ (Refer to "Derating", Instruction Manual 1 and 3)		
	CURRENT[A]	ACIN 100V	1.4typ (Io=100%)	
		ACIN 200V	0.7typ (Io=100%)	
	FREQUENCY[Hz]	50 / 60 (47 - 63)		
	EFFICIENCY[%]	ACIN 100V	84.0typ (Io=100%)	
		ACIN 200V	86.0typ (Io=100%)	
	POWER FACTOR	ACIN 100V	0.99typ (Io=100%)	
INRUSH CURRENT[A]	ACIN 100V	15typ (Io=100%) (At cold start) (Ta=25°C)		
	ACIN 200V	30typ (Io=100%) (At cold start) (Ta=25°C)		
LEAKAGE CURRENT[mA]	0.10 / 0.25max (ACIN 100V / 240V 60Hz, Io=100%, According to IEC60601-1)			
OUTPUT	VOLTAGE[V]	24	24	
	CURRENT[A]	4.3	4.3 (Peak 8.6) *2	
	LINE REGULATION[mV]	*7 96max	96max	
	LOAD REGULATION[mV]	*7 150max	150max	
	RIPPLE[mVp-p]	*3 0 to +50°C	120max	120max
		-10 - 0°C	160max	160max
	RIPPLE NOISE[mVp-p]*3	0 to +50°C	150max	150max
		-10 - 0°C	180max	180max
	TEMPERATURE REGULATION[mV]	0 to +50°C	240max	240max
		-10 to +50°C	290max	290max
	DRIFT[mV]	*4 96max	96max	
	START-UP TIME[ms]	350typ (ACIN 100V, Io=100%)		
	HOLD-UP TIME[ms]	20typ (ACIN 100V, Io=100%)		
OUTPUT VOLTAGE ADJUSTMENT RANGE[V]	19.20 to 27.50			
OUTPUT VOLTAGE SETTING[V]	24.00 to 24.96			
PROTECTION CIRCUIT AND OTHERS	OVERCURRENT PROTECTION	Works over 105% of rating (works over 101% of peak current at option -H) and recovers automatically		
	OVERVOLTAGE PROTECTION[V]	27.60 to 33.60	27.60 to 33.60	
	OPERATING INDICATION	Not provided		
	REMOTE SENSING	Not provided		
ISOLATION	REMOTE ON/OFF	Option (Required external power source.)		
	INPUT-OUTPUT-RC	*6 AC4,000V 1minute, Cutoff current = 10mA, DC500V 50MΩ min (At Room Temperature) 2MOOP		
	INPUT-FG	AC2,000V 1minute, Cutoff current = 10mA, DC500V 50MΩ min (At Room Temperature) 1MOOP		
	OUTPUT-RC-FG	*6 AC500V 1minute, Cutoff current = 25mA, DC500V 50MΩ min (At Room Temperature)		
	OUTPUT-RC	*6 AC100V 1minute, Cutoff current = 25mA, DC100V 10MΩ min (At Room Temperature)		
ENVIRONMENT	OPERATING TEMP., HUMID. AND ALTITUDE *5	-10 to +70°C, 20 - 90%RH (Non condensing), (Refer to "Derating", Instruction Manual 3) 3,000m (10,000feet) max		
	STORAGE TEMP., HUMID. AND ALTITUDE	-20 to +75°C, 20 - 90%RH (Non condensing), 9,000m (30,000feet) max		
	VIBRATION	10 - 55Hz, 19.6m/s ² (2G), 3minutes period, 60minutes each along X, Y and Z axis		
SAFETY AND NOISE REGULATIONS	IMPACT	196.1m/s ² (20G), 11ms, once each X, Y and Z axis		
	AGENCY APPROVALS (AT ONLY AC input)	ANSI/AAMI ES60601-1, EN60601-1 3rd, Complies with IEC60601-1-2 4th Ed.		
	CONDUCTED NOISE	Complies with FCC-B, VCCI-B, CISPR22-B, EN55011-B, EN55022-B		
OTHERS	HARMONIC ATTENUATOR	Complies with IEC61000-3-2 (Class A) *8		
	CASE SIZE/WEIGHT	62 X 33 X 155mm [2.44 X 1.30 X 6.10 inches] (W X H X D) / 290g max (with chassis & cover : 470g max)		
	COOLING METHOD	Convection (Refer to "Derating", Instruction Manual 3) *5		

*1 Specification is changed at option, refer to Instruction Manual.

*2 Peak loading for 10sec. And Duty 40% max.

() means peak current. There is a possibility that an internal device is damaged when the specification is exceeded.

*3 This is the value that measured on measuring board with capacitor of 22 μF at 150mm from output terminal.
Measured by 20MHz oscilloscope or Ripple-Noise meter (Equivalent to KEISOKU-GIKEN: RM103).

*4 Drift is the change in DC output for an eight hour period after a half-hour warm-up at 25°C, with the input voltage held constant at the rated input/output.

*5 Derating is required.

*6 Applicable when remote control (optional) is added.

*7 Please contact us about dynamic load and input response.

*8 Please contact us about another class.

* To meet the specifications. Do not operate over-loaded condition.

* Parallel operation is not possible.

* Derating is required when operated with chassis and cover.

* Sound noise may be generated by power supply in case of pulse load.

Block diagram

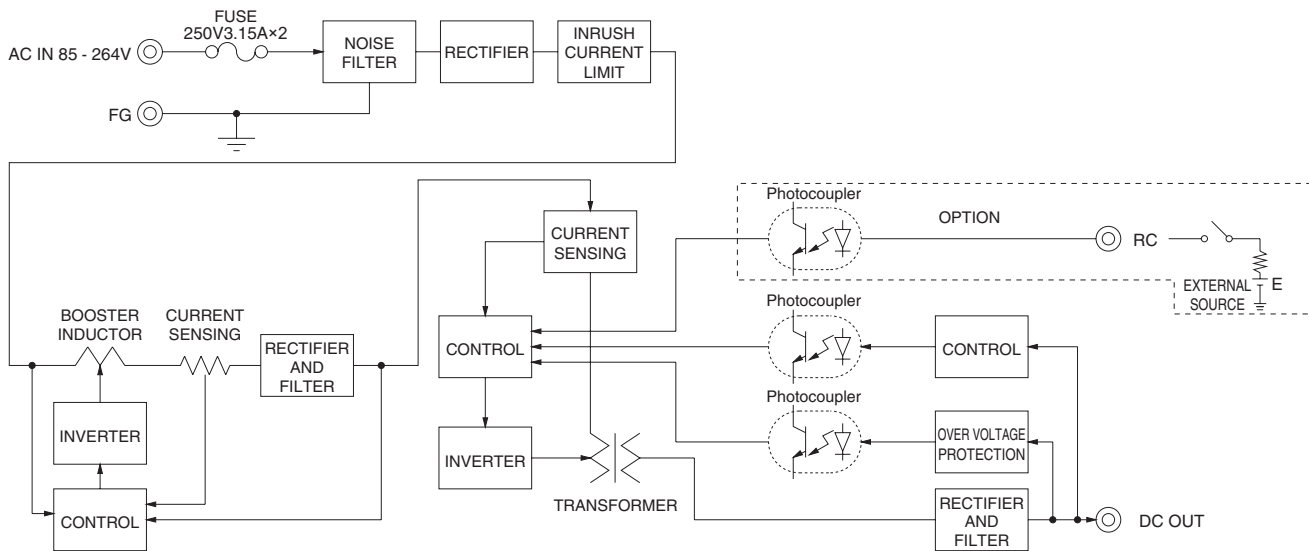

External view

※ External size of option is different from standard model.

Standard type

Chassis and cover type

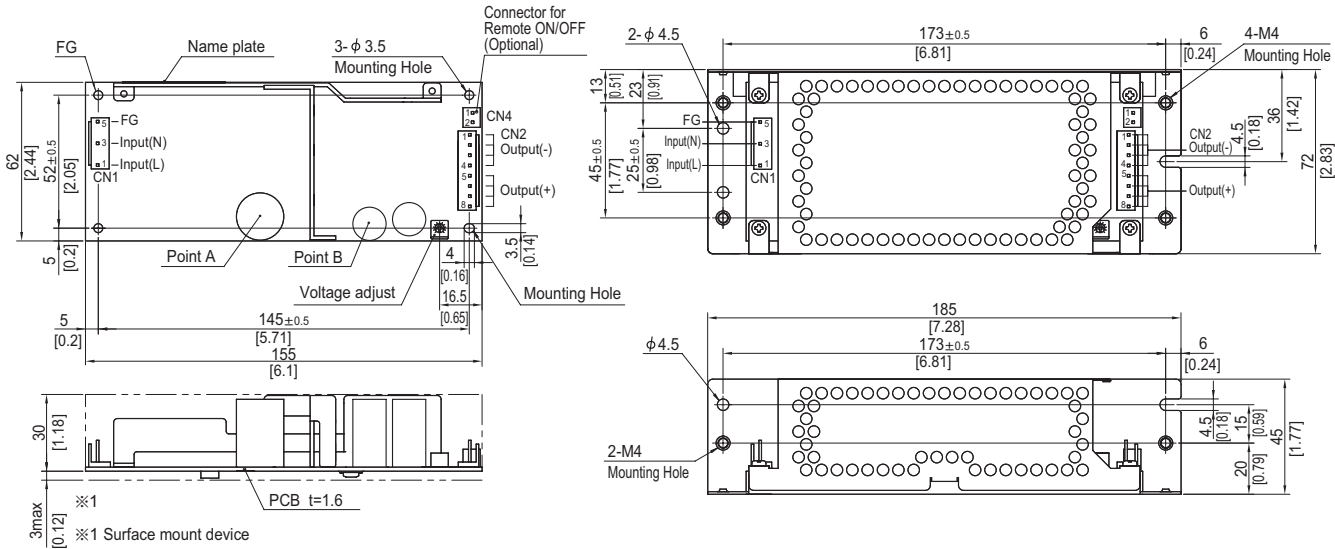

- ※ 4 Mounting holes are existing.
- ※ The back side of P.C.B. of the power supply is assembled some SMDs.
Be attention not to bump against the attached area by vibration.
- ※ Use the spacer of 8mm length or more regarding insulation.
And do not use press-fitting bush.
- ※ Point A, Point B are thermometry points.

I/O Connector	Mating connector	Terminal
CN1	1-1123724-3	Chain 1123721-1 Loose 1318912-1
CN2	1-1123723-8	Chain 1123721-1 Loose 1318912-1

(Mfr:Tyco Electronics)

- ※ I/O Connector is Mfr. Tyco Electronics
- ※ Option:-J1:VH(J.S.T) connector type.

<PIN CONNECTION>

CN1		CN2	
Pin No.	Input	Pin No.	Output
1	AC(L)	1 to 4	-V
2		5 to 8	+V
3	AC(N)		
4			
5	FG		

※ Keep drawing current per pin below 5A for CN2.

- ※ Tolerance : ±1 [±0.04]
- ※ Weight : 290g max (with chassis & cover : 470g max)
- ※ PCB material : CEM3
- ※ Optional chassis and cover material : Electric galvanizing steel board.
- ※ Dimensions in mm, []=inches
- ※ Mounting torque (Mounting hole of chassis) : 1.5N · m (16kgf · cm) max

Connector type

CN4 Option (Mfr:J.S.T)

PIN No.	Contents
1	RC(+)
2	RC(-)

Barrier strip type

Model B2B-XH-A
Mating Connector (Terminal)
XHP-2
(BXH-001T-P0.6
or SXH-001T-P0.6)

LMA150F

LM A 150 F -□ -□
 ① ② ③ ④ ⑤ ⑥

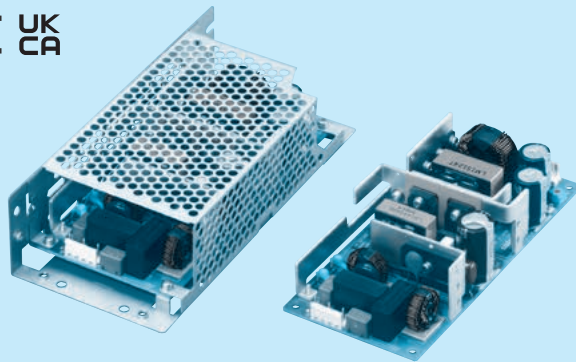

Example recommended EMI/EMC filter
NAM-04-101



High voltage pulse noise type : NAP series
 Low leakage current type : NAM series
 * A higher current rating EMI/EMC filter may be recommended in view of the other devices that could be connected in parallel with the power supply.

- ① Series name
 - ② Single output
 - ③ Output wattage
 - ④ Universal input
 - ⑤ Output voltage
 - ⑥ Optional *1
- C : with Coating
 G : Low leakage current
 H : with the function to be acceptable to output peak current
 J1 : VH(J.S.T.)connector type
 R : with Remote ON/OFF
 R2 : with Remote ON/OFF
 S : with Chassis
 SN : with Chassis & cover
 P : Setting in the overcurrent protection rating

This power supply is manufactured by SMD technology. The stress to P.C.B like twisting or bending causes the defect of the unit, so handle the unit with care.
 *Make sure necessary tests will be carried out on your end equipment with the power supply installed in accordance with any required EMC/EMI regulations.

MODEL	LMA150F-24-Y	LMA150F-24-HY
MAX OUTPUT WATTAGE[W]	151.2	151.2 (302.4) *2
DC OUTPUT	24V 6.3A	24V 6.3A (12.6A) *2

SPECIFICATIONS

	MODEL	LMA150F-24-Y	LMA150F-24-HY	
INPUT	VOLTAGE[V]	AC85 - 264 1 φ (Refer to "Derating", Instruction Manual 1 and 3)		
	CURRENT[A]	ACIN 100V	2.0typ (Io=100%)	
		ACIN 200V	1.0typ (Io=100%)	
	FREQUENCY[Hz]	50 / 60 (47 - 63)		
	EFFICIENCY[%]	ACIN 100V	85.0typ (Io=100%)	
		ACIN 200V	87.0typ (Io=100%)	
	POWER FACTOR	ACIN 100V	0.99typ (Io=100%)	
INRUSH CURRENT[A]	ACIN 100V	15typ (Io=100%) (At cold start) (Ta=25°C)		
	ACIN 200V	30typ (Io=100%) (At cold start) (Ta=25°C)		
LEAKAGE CURRENT[mA]	0.10 / 0.25max (ACIN 100V / 240V 60Hz, Io=100%, According to IEC60601-1)			
OUTPUT	VOLTAGE[V]	24		
	CURRENT[A]	6.3		
	LINE REGULATION[mV]	*7 96max		
	LOAD REGULATION[mV]	*7 150max		
	RIPPLE[mVp-p]	*3 0 to +50°C	120max	
		-10 - 0°C	160max	
	RIPPLE NOISE[mVp-p]*3	0 to +50°C	150max	
		-10 - 0°C	180max	
	TEMPERATURE REGULATION[mV]	0 to +50°C	240max	
		-10 to +50°C	290max	
	DRIFT[mV]	*4 96max		
	START-UP TIME[ms]	350typ (ACIN 100V, Io=100%)		
	HOLD-UP TIME[ms]	20typ (ACIN 100V, Io=100%)		
OUTPUT VOLTAGE ADJUSTMENT RANGE[V]	19.20 to 27.50			
OUTPUT VOLTAGE SETTING[V]	24.00 to 24.96			
PROTECTION CIRCUIT AND OTHERS	OVERCURRENT PROTECTION	Works over 105% of rating (works over 101% of peak current at option -H) and recovers automatically		
	OVERVOLTAGE PROTECTION[V]	27.60 to 33.60		
	OPERATING INDICATION	Not provided		
	REMOTE SENSING	Not provided		
ISOLATION	REMOTE ON/OFF	Option (Required external power source.)		
	INPUT-OUTPUT-RC	*6 AC4,000V 1minute, Cutoff current = 10mA, DC500V 50MΩ min (At Room Temperature) 2MOOP		
	INPUT-FG	AC2,000V 1minute, Cutoff current = 10mA, DC500V 50MΩ min (At Room Temperature) 1MOOP		
	OUTPUT-RC-FG	*6 AC500V 1minute, Cutoff current = 25mA, DC500V 50MΩ min (At Room Temperature)		
ENVIRONMENT	OUTPUT-RC	*6 AC100V 1minute, Cutoff current = 25mA, DC100V 10MΩ min (At Room Temperature)		
	OPERATING TEMP., HUMID. AND ALTITUDE *5	-10 to +70°C, 20 - 90%RH (Non condensing), (Refer to "Derating", Instruction Manual 3) 3,000m (10,000feet) max		
	STORAGE TEMP., HUMID. AND ALTITUDE	-20 to +75°C, 20 - 90%RH (Non condensing), 9,000m (30,000feet) max		
	VIBRATION	10 - 55Hz, 19.6m/s ² (2G), 3minutes period, 60minutes each along X, Y and Z axis		
SAFETY AND NOISE REGULATIONS	IMPACT	196.1m/s ² (20G), 11ms, once each X, Y and Z axis		
	AGENCY APPROVALS (AT ONLY AC input)	ANSI/AAMI ES60601-1, EN60601-1 3rd, Complies with IEC60601-1-2 4th Ed.		
	CONDUCTED NOISE	Complies with FCC-B, VCCI-B, CISPR22-B, EN55011-B, EN55022-B		
	HARMONIC ATTENUATOR	Complies with IEC61000-3-2 (Class A) *8		
OTHERS	CASE SIZE/WEIGHT	75 X 36.5 X 160mm [2.95 X 1.44 X 6.30 inches] (W X H X D) / 370g max (with chassis & cover : 600g max)		
	COOLING METHOD	Convection (Refer to "Derating", Instruction Manual 3) *5		

*1 Specification is changed at option, refer to Instruction Manual.
 *2 Peak loading for 10sec. And Duty 40% max.
 () means peak current. There is a possibility that an internal device is damaged when the specification is exceeded.
 *3 This is the value that measured on measuring board with capacitor of 22 μF at 150mm from output terminal.
 Measured by 20MHz oscilloscope or Ripple-Noise meter (Equivalent to KEISOKU-GIKEN: RM103).

*4 Drift is the change in DC output for an eight hour period after a half-hour warm-up at 25°C, with the input voltage held constant at the rated input/output.
 *5 Derating is required.
 *6 Applicable when remote control (optional) is added.
 *7 Please contact us about dynamic load and input response.
 *8 Please contact us about another class.

* To meet the specifications. Do not operate over-loaded condition.
 * Parallel operation is not possible.
 * Derating is required when operated with chassis and cover.
 * Sound noise may be generated by power supply in case of pulse load.

Block diagram

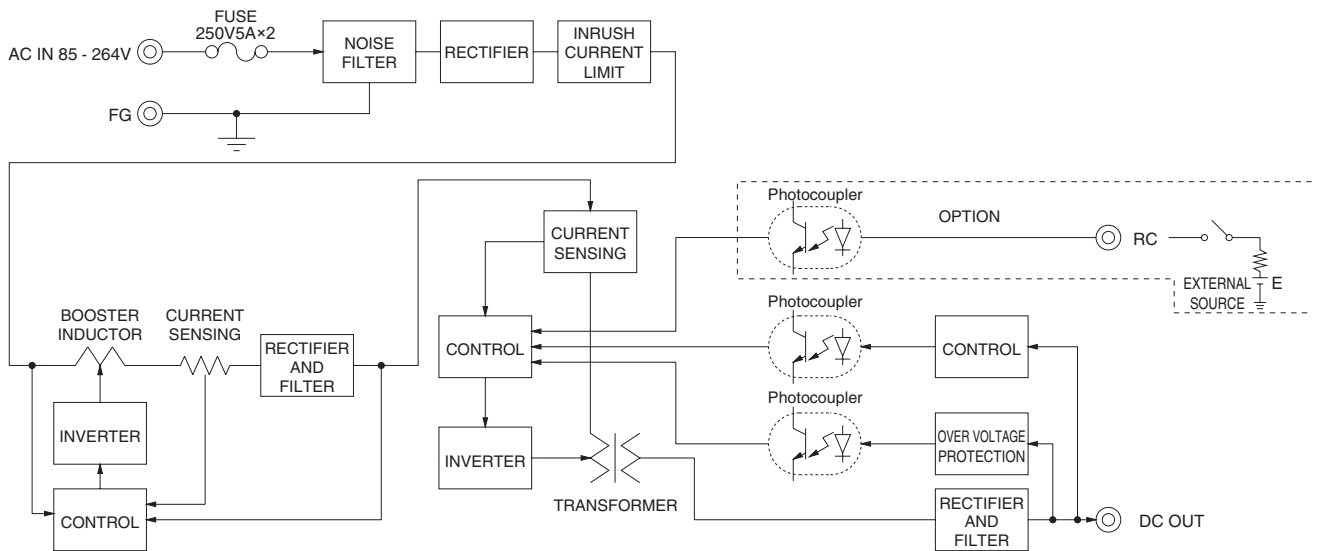

External view

※ External size of option is different from standard model.

Standard type

Chassis and cover type

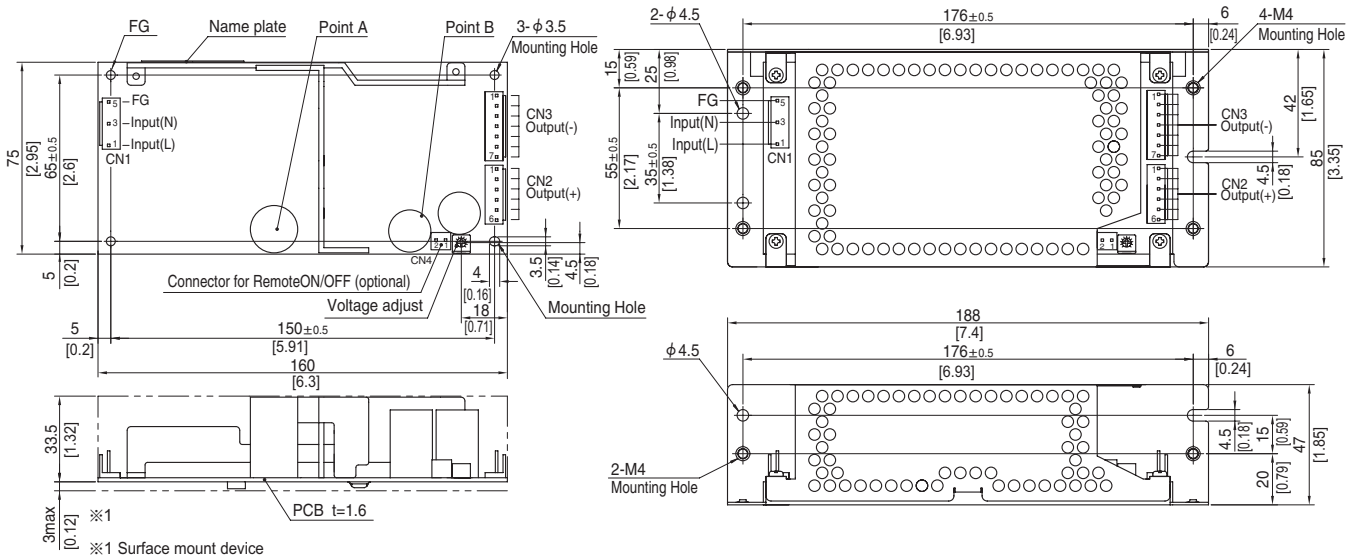

- ※ 1 Surface mount device
- ※ 4 Mounting holes are existing.
- ※ The back side of P.C.B. of the power supply is assembled some SMDs.
- Be attention not to bump against the attached area by vibration.
- ※ Use the spacer of 8mm length or more regarding insulation.
- And do not use press-fitting bush.
- ※ Point A, Point B are thermometry points.

<PIN CONNECTION>

I/O Connector	Mating connector	Terminal	Terminal
CN1	1-1123724-3	1-1123722-5	Chain 1123721-1
			Loose 1318912-1
CN2	1-1123723-6	1-1123722-6	Chain 1123721-1
			Loose 1318912-1
CN3	1-1123723-7	1-1123722-7	Chain 1123721-1
			Loose 1318912-1

(Mfr: Tyco Electronics)

- ※ I/O Connector is Mfr. Tyco Electronics
- ※ Option: -J1:VH(J.S.T) connector type.

CN1		CN2		CN3	
Pin No.	Input	Pin No.	Output	Pin No.	Output
1	AC(L)	1 to 6	+V	1 to 7	-V
2					
3	AC(N)				
4					
5	FG				

※ Keep drawing current per pin below 5A for CN2, CN3.

- ※ Tolerance : ± 1 [± 0.04]
- ※ Weight : 370g max (with chassis & cover : 600g max)
- ※ PCB material : CEM3
- ※ Optional chassis and cover material : Electric galvanizing steel board.
- ※ Dimensions in mm, []=inches
- ※ Mounting torque (Mounting hole of chassis) : $1.5N \cdot m$ (16kgf · cm) max

Connector type

CN4 Option (Mfr:J.S.T)

PIN No.	Contents
1	RC(+)
2	RC(-)

Barrier strip type

Model B2B-XH-A
Mating Connector (Terminal)
XHP-2
(BXH-001T-P0.6
or SXH-001T-P0.6)

LMA240F

LM A 240 F -□ -□

① ② ③ ④ ⑤ ⑥

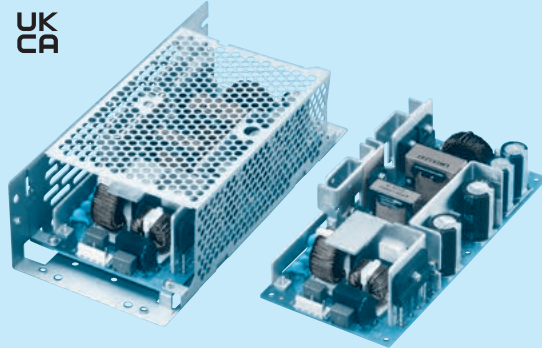

Example recommended EMI/EMC filter
NAM-06-101



High voltage pulse noise type : NAP series
Low leakage current type : NAM series
* A higher current rating EMI/EMC filter may be recommended in view of the other devices that could be connected in parallel with the power supply.

- ① Series name
- ② Single output
- ③ Output wattage
- ④ Universal input
- ⑤ Output voltage
- ⑥ Optional *1
- C : with Coating
- G : Low leakage current
- H : with the function to be acceptable to output peak current
- J1 : VH(J.S.T.)connector type
- R : with Remote ON/OFF
- S : with Chassis
- SN : with Chassis & cover
- P : Setting in the overcurrent protection rating

This power supply is manufactured by SMD technology. The stress to P.C.B like twisting or bending causes the defect of the unit, so handle the unit with care.
*Make sure necessary tests will be carried out on your end equipment with the power supply installed in accordance with any required EMC/EMI regulations.

MODEL	LMA240F-24-Y	LMA240F-24-HY
MAX OUTPUT WATTAGE[W]	300	300 (480) *2
DC OUTPUT	Convection	24V 10A
	Forced air	24V 12.5A
		24V 12.5A (20A) *2

SPECIFICATIONS

	MODEL	LMA240F-24-Y	LMA240F-24-HY	
INPUT	VOLTAGE[V]	AC85 - 264 1 φ (Refer to "Derating", Instruction Manual 1 and 3)		
	CURRENT[A]	ACIN 100V	3.9typ (Io=100%)	
		ACIN 200V	1.8typ (Io=100%)	
	FREQUENCY[Hz]	50 / 60 (47 - 63)		
	EFFICIENCY[%]	ACIN 100V	86.0typ (Io=100%)	
		ACIN 200V	88.0typ (Io=100%)	
	POWER FACTOR	ACIN 100V	0.99typ (Io=100%)	
		ACIN 200V	0.95typ (Io=100%)	
	INRUSH CURRENT[A]	ACIN 100V	15 / 30typ (Io=100%) (Primary inrush current /Secondary inrush current) (More than 3 sec. to re-start)	
		ACIN 200V	30 / 30typ (Io=100%) (Primary inrush current /Secondary inrush current) (More than 3 sec. to re-start)	
LEAKAGE CURRENT[ma]	0.15 / 0.40max (ACIN 100V / 240V 60Hz, Io=100%, According to IEC60601-1)			
OUTPUT	VOLTAGE[V]	24	24	
	CURRENT[A]	Convection	10	10 (Peak 20) *2
		Forced air	12.5	12.5 (Peak 20) *2
	LINE REGULATION[mV] *7	96max		
	LOAD REGULATION[mV] *7	150max		
	RIPPLE[mVp-p] *3	0 to +50°C	120max	120max
		-10 - 0°C	160max	160max
	RIPPLE NOISE[mVp-p]*3	0 to +50°C	150max	150max
		-10 - 0°C	180max	180max
	TEMPERATURE REGULATION[mV]	0 to +50°C	240max	240max
		-10 to +50°C	290max	290max
	DRIFT[mV] *4	96max		
	START-UP TIME[ms]	350typ (ACIN 100V, Io=100%)		
	HOLD-UP TIME[ms] *9	20typ (ACIN 100V, Io=100%)		
OUTPUT VOLTAGE ADJUSTMENT RANGE[V]	19.20 to 27.50			
OUTPUT VOLTAGE SETTING[V]	24.00 to 24.96			
PROTECTION CIRCUIT AND OTHERS	OVERCURRENT PROTECTION	Works over 105% of rating (works over 101% of peak current at option -H) and recovers automatically		
	OVERVOLTAGE PROTECTION[V]	27.60 to 33.60		
	OPERATING INDICATION	Not provided		
	REMOTE SENSING	Not provided		
REMOTE ON/OFF	Option (Required external power source.)			
ISOLATION	INPUT-OUTPUT-RC *6	AC4,000V 1minute, Cutoff current = 10mA, DC500V 50MΩ min (At Room Temperature) 2MOOP		
	INPUT-FG	AC2,000V 1minute, Cutoff current = 10mA, DC500V 50MΩ min (At Room Temperature) 1MOOP		
	OUTPUT-RC-FG *6	AC500V 1minute, Cutoff current = 25mA, DC500V 50MΩ min (At Room Temperature)		
	OUTPUT-RC *6	AC100V 1minute, Cutoff current = 25mA, DC100V 10MΩ min (At Room Temperature)		
ENVIRONMENT	OPERATING TEMP., HUMID. AND ALTITUDE *5	-10 to +70°C, 20 - 90%RH (Non condensing), (Refer to "Derating", Instruction Manual 3) 3,000m (10,000feet) max		
	STORAGE TEMP., HUMID. AND ALTITUDE	-20 to +75°C, 20 - 90%RH (Non condensing), 9,000m (30,000feet) max		
	VIBRATION	10 - 55Hz, 19.6m/s ² (2G), 3minutes period, 60minutes each along X, Y and Z axis		
SAFETY AND NOISE REGULATIONS	IMPACT	196.1m/s ² (20G), 11ms, once each X, Y and Z axis		
	AGENCY APPROVALS (AT ONLY AC input)	ANSI/AAMI ES60601-1, EN60601-1 3rd, Complies with IEC60601-1-2 4th Ed.		
	CONDUCTED NOISE	Complies with FCC-B, VCCI-B, CISPR22-B, EN55011-B, EN55022-B		
OTHERS	HARMONIC ATTENUATOR	Complies with IEC61000-3-2 (Class A) *8		
	CASE SIZE/WEIGHT	84 X 46 X 180mm [3.31 X 1.81 X 7.09 inches] (W X H X D) / 540g max (with chassis & cover : 860g max)		
	COOLING METHOD	Convection / Forced air (Refer to "Derating", Instruction Manual 3) *5		

*1 Specification is changed at option, refer to Instruction Manual.

*2 Peak loading for 10sec. And Duty 40% max.
() means peak current. There is a possibility that an internal device is damaged when the specification is exceeded.

*3 This is the value that measured on measuring board with capacitor of 22 μF at 150mm from output terminal.
Measured by 20MHz oscilloscope or Ripple-Noise meter (Equivalent

to KEISOKU-GIKEN: RM103).

*4 Drift is the change in DC output for an eight hour period after a half-hour warm-up at 25°C, with the input voltage held constant at the rated input/output.

*5 Derating is required.

*6 Applicable when remote control (optional) is added.

*7 Please contact us about dynamic load and input response.

*8 Please contact us about another class.

* To meet the specifications. Do not operate over-loaded condition.

* Parallel operation is not possible.

* Derating is required when operated with chassis and cover.

* Sound noise may be generated by power supply in case of pulse load.

Block diagram

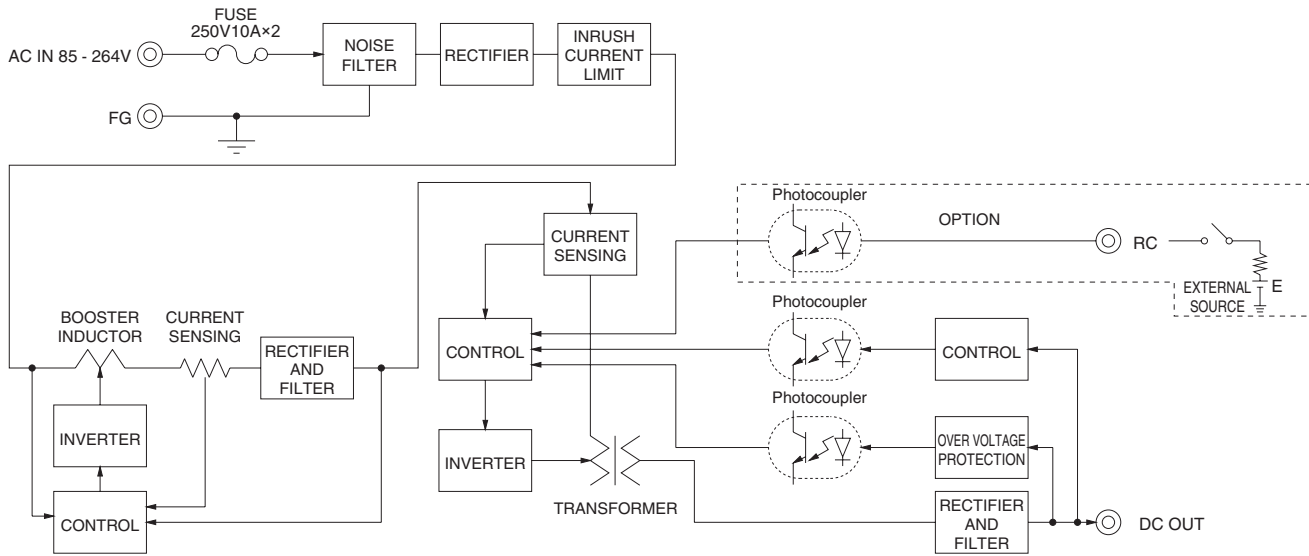

External view

※ External size of option is different from standard model.

Standard type

Chassis and cover type

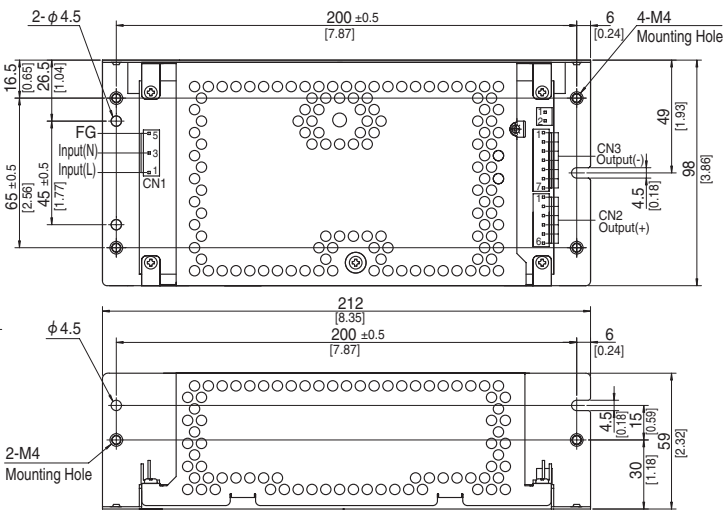
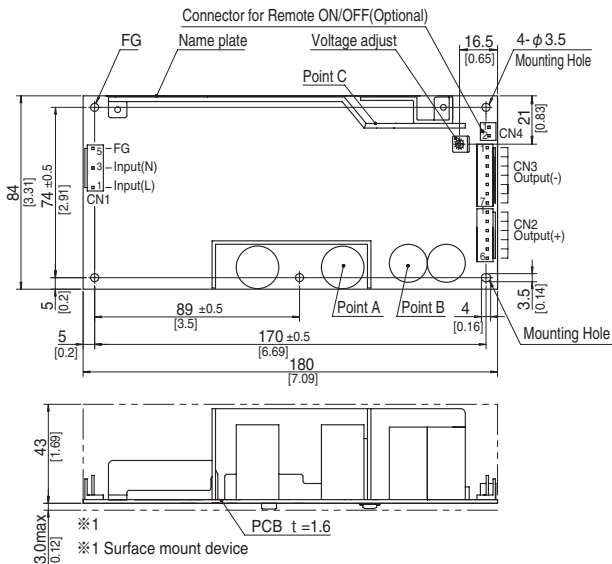

- ※ 5 Mounting holes are existing.
- ※ The back side of P.C.B. of the power supply is assembled some SMDs.
Be attention not to bump against the attached area by vibration.
- ※ Use the spacer of 8mm length or more regarding insulation.
And do not use press-fitting bush.
- ※ Point A, Point B, Point C are thermometry points.

I/O Connector	Mating connector	Terminal
CN1	1-1123724-3	Chain 1123721-1
		Loose 1318912-1
CN2	1-1123723-6	Chain 1123721-1
		Loose 1318912-1
CN3	1-1123722-7	Chain 1123721-1
		Loose 1318912-1

(Mfr:Tyco Electronics)

- ※ I/O Connector is Mfr. Tyco Electronics
- ※ Option:-J1:VH(J.S.T) connector type.

<PIN CONNECTION>

CN1		CN2		CN3	
Pin No.	Input	Pin No.	Output	Pin No.	Output
1	AC(L)	1 to 6	+V	1 to 7	-V
2					
3	AC(N)				
4					
5	FG				

※ Keep drawing current per pin below 5A for CN2,CN3.

- ※ Tolerance : ±1 [±0.04]
- ※ Weight : 540g max (with chassis & cover : 860g max)
- ※ PCB material : CEM3
- ※ Optional chassis and cover material : Electric galvanizing steel board.
- ※ Dimensions in mm, [] =inches
- ※ Mounting torque (Mounting hole of chassis) :1.5N · m (16kgf · cm) max

Connector type

CN4 Option (Mfr:J.S.T)

PIN No.	Contents
1	RC(+)
2	RC(-)

Barrier strip type

Model B2B-XH-A
Mating Connector (Terminal)
XHP-2
(BXH-001T-P0.6
or SXH-001T-P0.6)

Assembling and Installation Method

Installation method

■ This power supply is manufactured by SMD technology. The stress to P.C.B like twisting or bending causes the defect of the unit, so handle the unit with care.

■ In case of metal chassis, keep the distance between d1 & d2 for to insulate between lead of component and metal chassis, use the spacer of 8mm or more between d1. If it is less than d1 & d2, insert the insulation sheet between power supply and metal chassis.

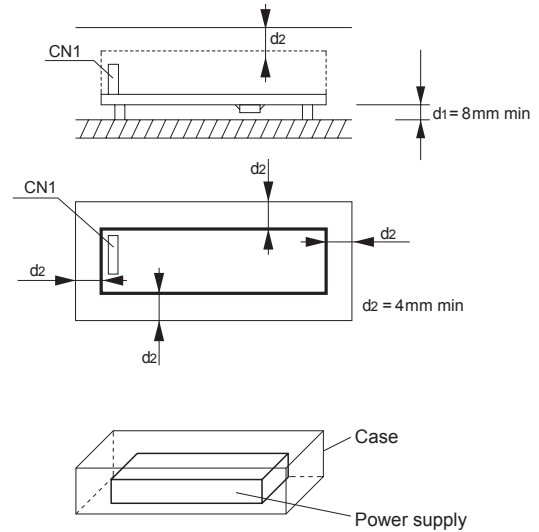

■ There is a possibility that it is not possible to cool enough when the power supply is used by the sealing up space as showing in right figure. Please use it after confirming the temperature of point A and point B of Instruction Manual 3.

■ (F) mounting is not possible when unit is with case cover, but if need to operate unit by (F) positioning with case cover, temperature / load derating is necessary. For more details, please contact our sales or engineering departments.

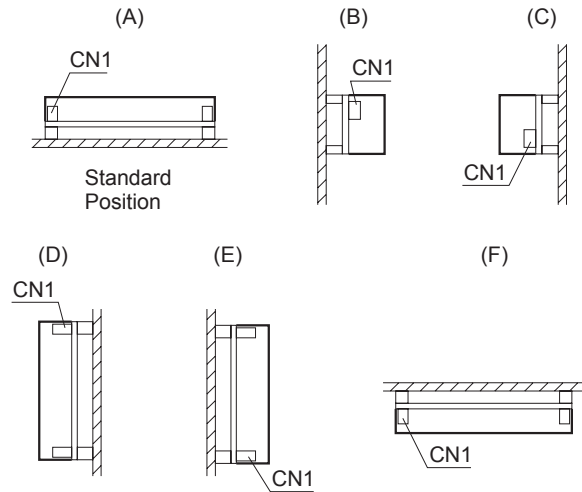

Mounting screw

■ The mounting screw should be M3. The hatched area shows the allowance of metal parts for mounting.

● LMA100F, LMA150F

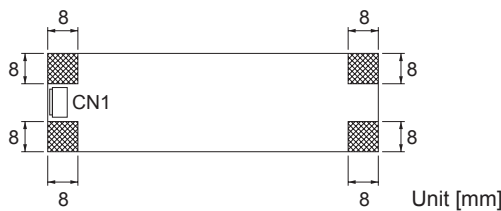

● LMA240F

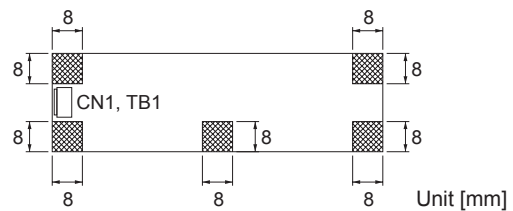

■ If metallic fittings are used on the component side of the board, ensure there is no contact with surface mounted components.
 ■ This product uses SMD technology. Please avoid the PCB installation method which includes the twisting stress or the bending stress.
 * Recommendation to electrically connect FG to metal chassis for reducing noise.

Derating

● Derating curve for input voltage

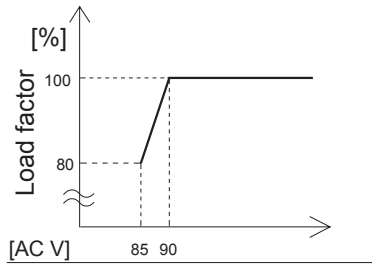

● LMA100F Ambient temperature derating curve (Reference value)

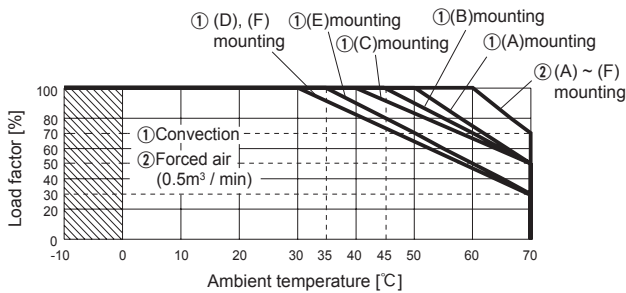

● LMA150F Ambient temperature derating curve (Reference value)

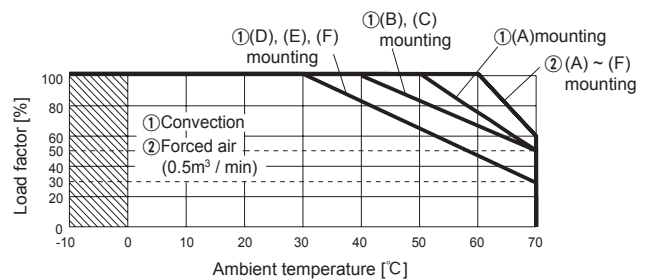

● LMA240F Ambient temperature derating curve (Reference value)

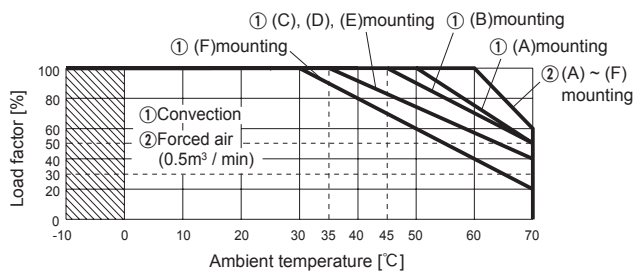

Output voltage	Output power[W]	
	①Convection	②Forced air
24V	240.0	300.0

- The operative ambient temperature is different by with / without chassis cover or mounting position.
Note: In the hatched area, the specification of Ripple, Ripple Noise is different from other area.
- Make sure the temperature at point A and point B is less than the temperatures shown in Instruction Manual 3.
- The ambient temperature should be measured 5 to 10 cm away from the power supply so that it won't be influenced by the heat from the power supply. Please consult us for more details.

Instruction Manual

◆ It is necessary to read the "Instruction Manual" and "Before using our product" before you use our product.

Basic Characteristics Data

Model	Circuit method	Switching frequency [kHz]	Input current *1 [A]	Inrush current protection	PCB/Pattern			Series/Parallel operation availability	
					Material	Single sided	Double sided	Series operation	Parallel operation
LMA100F	Active filter	60	1.4	Thermistor	CEM-3		Yes	Yes	No
	Forward converter	130							
LMA150F	Active filter	60	2.0	Thermistor	CEM-3		Yes	Yes	No
	Forward converter	130							
LMA240F	Active filter	60	3.9	SCR	CEM-3		Yes	Yes	No
	Forward converter	130							

*1 The value of input current is at ACIN 100V and rated load.

FORTEC

GROUP

Our company network supports you worldwide with offices in Germany, Austria, Switzerland, the UK and the USA. For more information please contact:

FORTEC

GROUP

FORTEC Elektronik AG | Augsburgener Straße 2b | 82110 Germering
+49 89 894450-0
info@fortecag.de | www.fortecag.de

FORTEC

INTEGRATED

FORTEC Integrated GmbH | Augsburgener Straße 2b | 82110 Germering
+49 89 894363-0
info@fortec-integrated.de | www.fortec-integrated.de

FORTEC

POWER

FORTEC Power GmbH | Lise-Meitner-Straße 3 | 64560 Riedstadt
+49 6158 8285-0
weborder@fortec-power.de | www.fortec-power.de

FORTEC

EGYPT

FORTEC Electronic Design and Solution Egypt SMLC | Linx Business Park
Unit B318 | Smart Village | Giza Governorate
info@fortec-integrated.de | www.fortec-integrated.de

Autronic Steuer- und Regeltechnik GmbH | Siemensstraße 17
74343 Sachsenheim
+49 7147 24-0
vertrieb@autronic.de | www.autronic.de

FORTEC

CZECH REPUBLIC

FORTEC Czech Republic s.r.o. | Přátelství 275 | 330 02 Dýšina
+49 89 894363-0
info@fortec.cz | www.fortec.cz

FORTEC

UNITED STATES

FORTEC United States, Corp. | 87 Raynor Avenue Unit 1 | Ronkonkoma
NY | 11779 | +1 631 5804360
info@fortec.us | www.fortec.us

FORTEC

SWITZERLAND

FORTEC Switzerland AG | Bahnhofstraße 3 | 5436 Würenlos
+41 44 7446111
info@fortec.ch | www.fortec.ch

FORTEC

UNITED KINGDOM

FORTEC Technology UK Ltd. | Osprey House | 1 Osprey Court
Hinchingsbrooke Business Park | Huntingdon | Cambridgeshire | PE29 6FN
+44 1480 411600
info@fortec.uk | www.fortec.uk