



OUR GLOBAL
COMPETENCE
CENTRES

 APOLLO DISPLAY
TECHNOLOGIES



 DISTEC



 DISPLAY
TECHNOLOGY



Datasheet

Ampire

AM7201280HTZQW-00H

AM-10-006

The information contained in this document has been carefully researched and is, to the best of our knowledge, accurate. However, we assume no liability for any product failures or damages, immediate or consequential, resulting from the use of the information provided herein. Our products are not intended for use in systems in which failures of product could result in personal injury. All trademarks mentioned herein are property of their respective owners. All specifications are subject to change without notice.



晶采光電科技股份有限公司
AMPIRE CO., LTD.

SPECIFICATIONS FOR LCD MODULE

CUSTOMER	
CUSTOMER PART NO.	
AMPIRE PART NO.	AM-7201280HTZQW-00H
APPROVED BY	
DATE	

- Approved For Specifications
 Approved For Specifications & Sample

AMPIRE CO., LTD.
Building A., 4F., No.116, Sec. 1, Sintai 5th Rd., Xizhi Dist,
New Taipei City 221, Taiwan (R.O.C.)
新北市汐止區新台五路一段 116 號 4 樓(東方科學園區 A 棟)
TEL:886-2-26967269 , FAX:886-2-26967196 or 26967270

APPROVED BY	CHECKED BY	ORGANIZED BY

RECORD OF REVISION

Revision Date	Page	Contents	Editor
2017/3/21	-	New Release Update T.B.D Data	Kokai Kokai

CONFIDENTIAL

1. PHYSICAL SPECIFICATIONS

Item	Specifications	Remark
LCD size	4.99 inch(Diagonal)	
Driver element	a-Si TFT active matrix	
Display resolution	720 (W) × 3(RGB) x 1280(H) dots	
Pixel Configuration	16.7M	
Pixel pitch	0.08625 (W) x0.08625 (H) mm	
Active area	62.1 (W) x 110.4 (H) mm	
Module size	65.0 (W) x 118.0 (H) × 1.48 (D) mm	
Color arrangement	R.G.B-stripe	
LED Numbers	12 LED (2 Parallel x 6 Serial)	
Weight (g)	TBD	
Driver IC	HX8394-F	
Interface	MIPI 4 lanes	

2. ABSOLUTE MAXIMUM RATINGS

GND=0V, Ta = 25°C

Item	Symbol	MIN	MAX	Unit	Remark
Analog Power Supply Voltage	AVDD	-0.3	6.6	V	
Digital Power Supply Voltage	IOVCC	-0.3	3.6	V	
Analog Power Supply Voltage	AVEE	-6.6	0	V	
Logic input Signals	V _{IN}	-0.3	IOVCC+0.3	V	
Back Light Forward Current	I _{LED}	-	25	mA	For Each LED
Operating Temperature	TOPR	-20	70	°C	
Storage Temperature	TSTG	-30	80	°C	

3. ELECTRICAL SPECIFICATIONS

3.1 Driving TFT LCD Panel

Item	Symbol	MIN	TYP	MAX	Unit	Remark
Digital Supply Voltage	IOVCC	1.7	1.8	3.6	V	
Analog Supply voltage	AVDD	5.2	5.5	6.5	V	
Analog Supply voltage	AVEE	-6.5	-5.5	-5.2	V	
Input Signal Voltage	Low Level V _{IL}	GND	--	0.2* IOVCC	V	RESX
	High Level V _{IH}	0.2* IOVCC	--	IOVCC	V	
Output Signal Voltage	Low Level V _{OL}	GND	--	0.2* IOVCC	V	FMARK , LED_PWM
	High Level V _{OH}	0.8* IOVCC	--	IOVCC	V	

3.2 Back-light Unit

Item	Symbol	Min.	Typ.	Max.	Unit	Note
LED Forward Current	IF	--	20*2	22*2	mA	Ta=25°C
LED Forward Voltage	VF	16	18.3	21	V	IF=40mA, Ta=25°C
LED life time			T.B.D	-	Hr	IF=40mA, Ta=25°C

Note 1 : The LED driving condition is defied for each LED module (6 LED Serial,2 LED Parallel).

Note 2 : Under LCM operating, the stable forward current should be inputted. And forward voltage is for reference only.

Note 3: If the module is driven by high current or at high ambient temperature & humidity condition. The operating life will be reduced.

Note 4: Operating life means brightness goes down to 50% minimum brightness. LED life time is estimated data. Ta=25°C

Note 5: the structure of LED B/L shows as below.

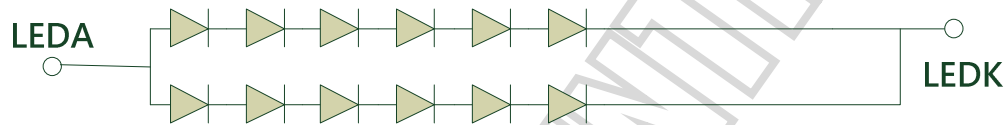

Note 7: When LCM is operated over 60°C ambient temperature, the I_{LED} of the LED back-light should be adjusted to 30mA max

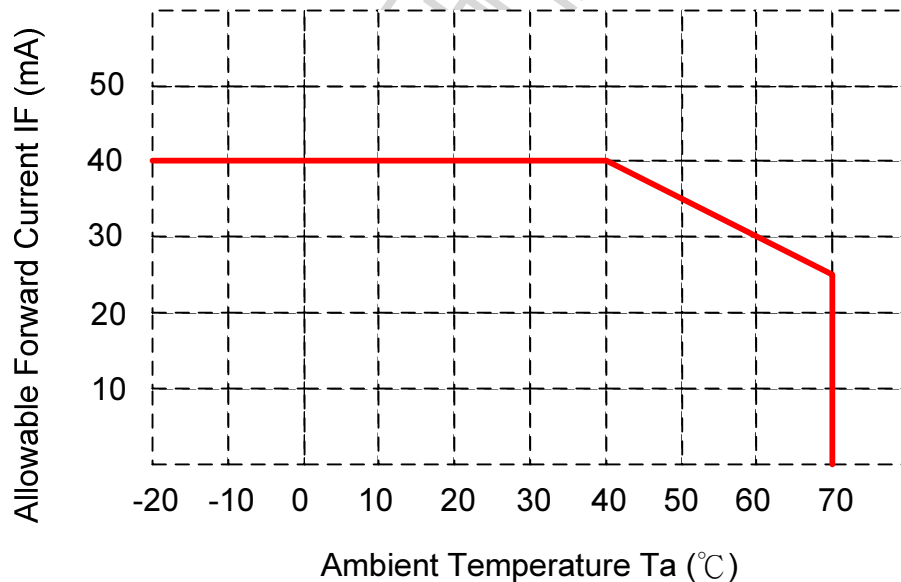

4 Input /Output Terminals

PIN NO	Symbol	I/O	Function
1	LEDK	P	Cathode of LED
2	LEDA	P	Anode of LED
3	NC	-	No connection
4	GND	P	Power ground
5	MIPI_DP0+	I	MIPI data Lane 0+
6	MIPI_DN0-	I	MIPI data Lane 0-
7	GND	P	Power ground
8	MIPI_DP1+	I	MIPI data Lane 1+
9	MIPI_DN1-	I	MIPI data Lane 1-
10	GND	P	Power ground
11	MIPI_CLKP+	I	MIPI Clock Lane +
12	MIPI_CLKN -	I	MIPI Clock Lane -
13	GND	P	Power ground
14	MIPI_DP2+	I	MIPI data Lane 2+
15	MIPI_DN2-	I	MIPI data Lane 2-
16	GND	P	Power ground
17	MIPI_DP3+	I	MIPI data Lane 3+
18	MIPI_DN3-	I	MIPI data Lane 3-
19	GND	P	Power ground
20	LED_PWM	O	Back-light Control PWM signal
21	FMARK	O	earing Effect
22	RESET	I	Reset Signal
23	GND	P	Power ground
24	NC	-	No connection
25	MTP	P	Programming Power
26	NC	-	No connection
27	NC	-	No connection
28	IOVCC	P	Digital Power Supply (1.7V ~ 3.6V)
29	NC	-	No connection
30	AVDD	P	Input voltage from the set-up circuit (5.2V to 6.5V)
31	AVEE	P	Input voltage from the set-up circuit (-5.2V to -6.5V)
32	NC	-	No connection
33	NC	-	No connection
34	NC	-	No connection

6 Optical Characteristics

Item	Symbol	Condition	Min	Typ	Max	Unit	Remark
View Angles	θT	$CR \geq 10$	70	80		Degree	Note2,3
	θB		70	80			
	θL		70	80			
	θR		70	80			
Contrast Ratio	CR	$\theta=0^\circ$	350	750			Note 3
Response Time	T_{ON}	25°C	-	30	35	ms	Note 4
	T_{OFF}						
Chromaticity	White	Backlight is on	x	0.2276	0.2876	0.3476	Note 1,5
			y	0.2478	0.2478	0.2478	
	Red		x	0.5804	0.5804	0.5804	Note 1,5
			y	0.2899	0.2899	0.2899	
	Green		x	0.2612	0.2612	0.2612	Note 1,5
			y	0.5544	0.5544	0.5544	
	Blue		x	0.1066	0.1066	0.1066	Note 1,5
			y	--	--	--	
Uniformity	U		80	--	--	%	Note 6
NTSC			--	69	--	%	Note 5
Luminance	L		280	360	--	cd/m ²	Note 7

Test Conditions:

1. $I_F = 20\text{mA}$ (One LED), and the ambient temperature is 25°C .
2. The test systems refer to Note 1 and Note 2.

Note 1: Definition of optical measurement system.

The optical characteristics should be measured in dark room. After 5 Minutes operation, the optical properties are measured at the center point of the LCD screen. All input terminals LCD panel must be ground when measuring the center area of the panel.

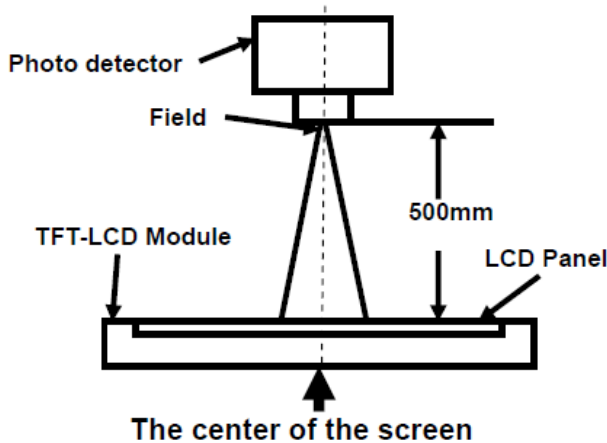

Item	Photo detector	Field
Contrast Ratio	SR-3A	1°
Luminance		
Chromaticity		
Lum Uniformity	BM-7A	2°
Response Time		

Note 2: Definition of viewing angle range and measurement system.

viewing angle is measured at the center point of the LCD by CONOSCOPE(ergo-80).

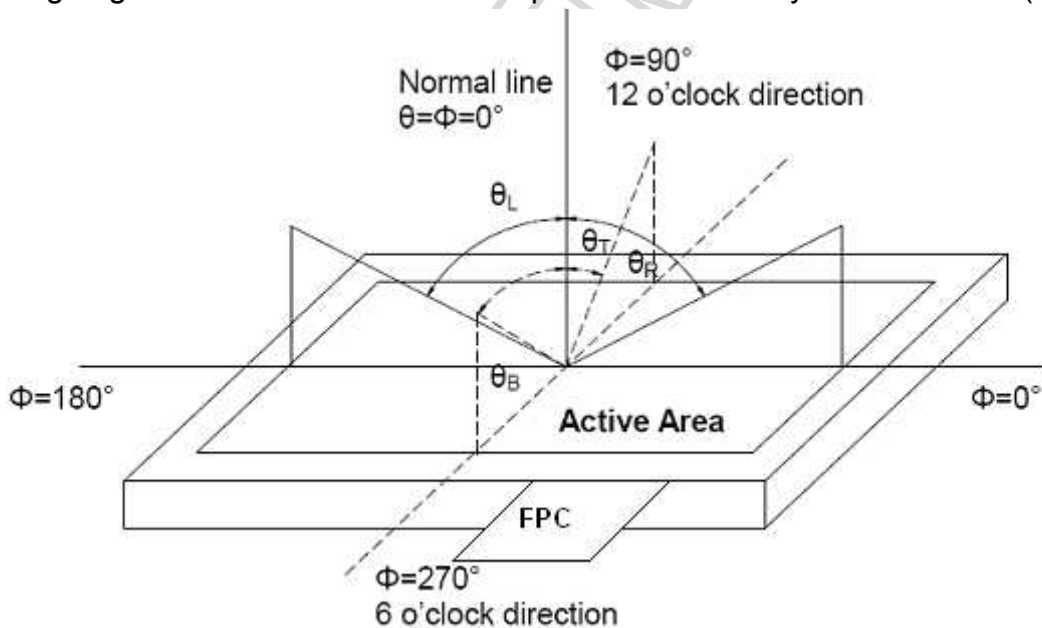

Note 3: Definition of contrast ratio

$$\text{Contrast ratio (CR)} = \frac{\text{Luminance measured when LCD is on the "White" state}}{\text{Luminance measured when LCD is on the "Black" state}}$$

“White state “: The state is that the LCD should drive by V_{white}.

“Black state”: The state is that the LCD should drive by V_{black}.

Vwhite: To be determined Vblack: To be determined.

Note 4: Definition of Response time

The response time is defined as the LCD optical switching time interval between “White” state and “Black” state. Rise time (T_{ON}) is the time between photo detector output intensity changed from 90% to 10%. And fall time (T_{OFF}) is the time between photo detector output intensity changed from 10% to 90%.

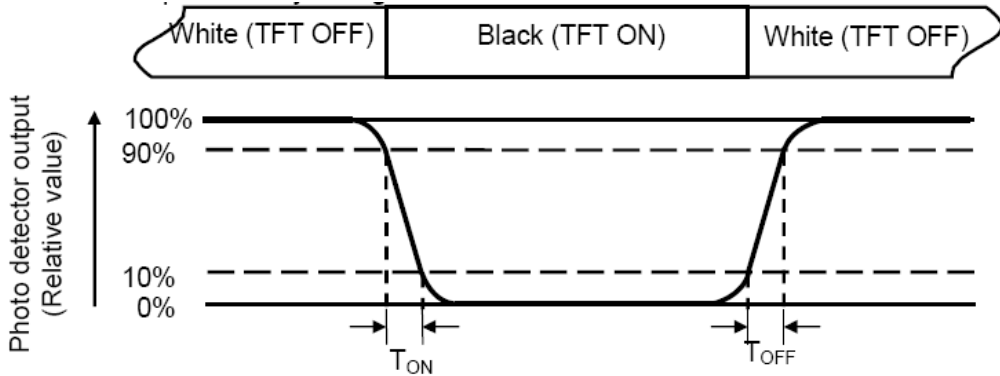

Note 5: Definition of color chromaticity (CIE1931)

Color coordinates measured at center point of LCD.

Note 6: Definition of Luminance Uniformity

Active area is divided into 9 measuring areas (Refer Fig. 2). Every measuring point is placed at the center of each measuring area.

Luminance Uniformity (U) = L_{min} / L_{max}

L-----Active area length W----- Active area width

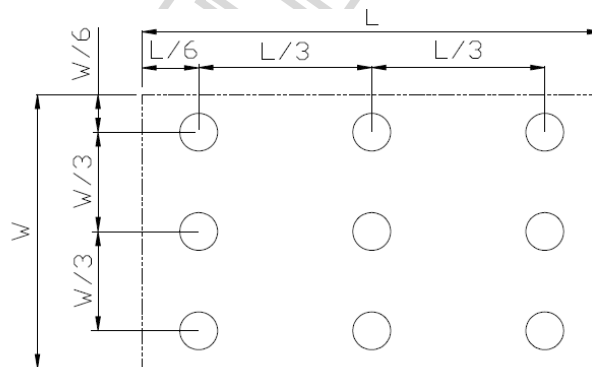

L_{max} : The measured Maximum luminance of all measurement position.

L_{min} : The measured Minimum luminance of all measurement position.

Note 7: Definition of Luminance:

Measure the luminance of white state at avg of 9 point.

7 Reliability Test

Test Item	Test Conditions	Note
High Temperature Operation	70±3°C , t=240 hrs	
Low Temperature Operation	-20±3°C , t=240 hrs	
High Temperature Storage	80±3°C , t=240 hrs	1,2
Low Temperature Storage	-30±3°C , t=240 hrs	1,2
Storage at High Temperature and Humidity	60°C, 90% RH , 240 hrs	1,2
Thermal Shock Test	-20°C (30min) ~ 70°C (30min) 100 cycles	1,2
Vibration Test (Packing)	Sweep frequency : 10 ~ 55 ~ 10 Hz/1min Amplitude : 0.75mm Test direction : X.Y.Z/3 axis Duration : 30min/each axis	2

Note 1 : Condensation of water is not permitted on the module.

Note 2 : The module should be inspected after 1 hour storage in normal conditions (15-35°C , 45-65%RH).

8 General Precautions

8-1 Safety

Liquid crystal is poisonous. Do not put it your month. If liquid crystal touches your skin or clothes, wash it off immediately by using soap and water.

8-2 Handling

1. The LCD panel is plate glass. Do not subject the panel to mechanical shock or to excessive force on its surface.
2. The polarizer attached to the display is easily damaged. Please handle it carefully to avoid scratch or other damages.
3. To avoid contamination on the display surface, do not touch the module surface with bare hands.
4. Keep a space so that the LCD panels do not touch other components.
5. Put cover board such as acrylic board on the surface of LCD panel to protect panel from damages.
6. Transparent electrodes may be disconnected if you use the LCD panel under environmental conditions where the condensation of dew occurs.
7. Do not leave module in direct sunlight to avoid malfunction of the ICs.

8-3 Static Electricity

1. Be sure to ground module before turning on power or operation module.
2. Do not apply voltage which exceeds the absolute maximum rating value.

8-4 Storage

1. Store the module in a dark room where must keep at $+25\pm 10^{\circ}\text{C}$ and 65%RH or less.
2. Do not store the module in surroundings containing organic solvent or corrosive gas.
3. Store the module in an anti-electrostatic container or bag.

8-5 Cleaning

1. Do not wipe the polarizer with dry cloth. It might cause scratch.
2. Only use a soft sloth with IPA to wipe the polarizer, other chemicals might permanent damage to the polarizer.

8-6 Others

1. AMIPRE will provide one year warrantee for all products and three months warrantee for all repairing products.
2. Do not keep the LCD at the same display pattern continually. The residual image will happen and it will damage the LCD. Please use screen saver

CONFIDENTIAL

9. OUTLINE DIMENSION

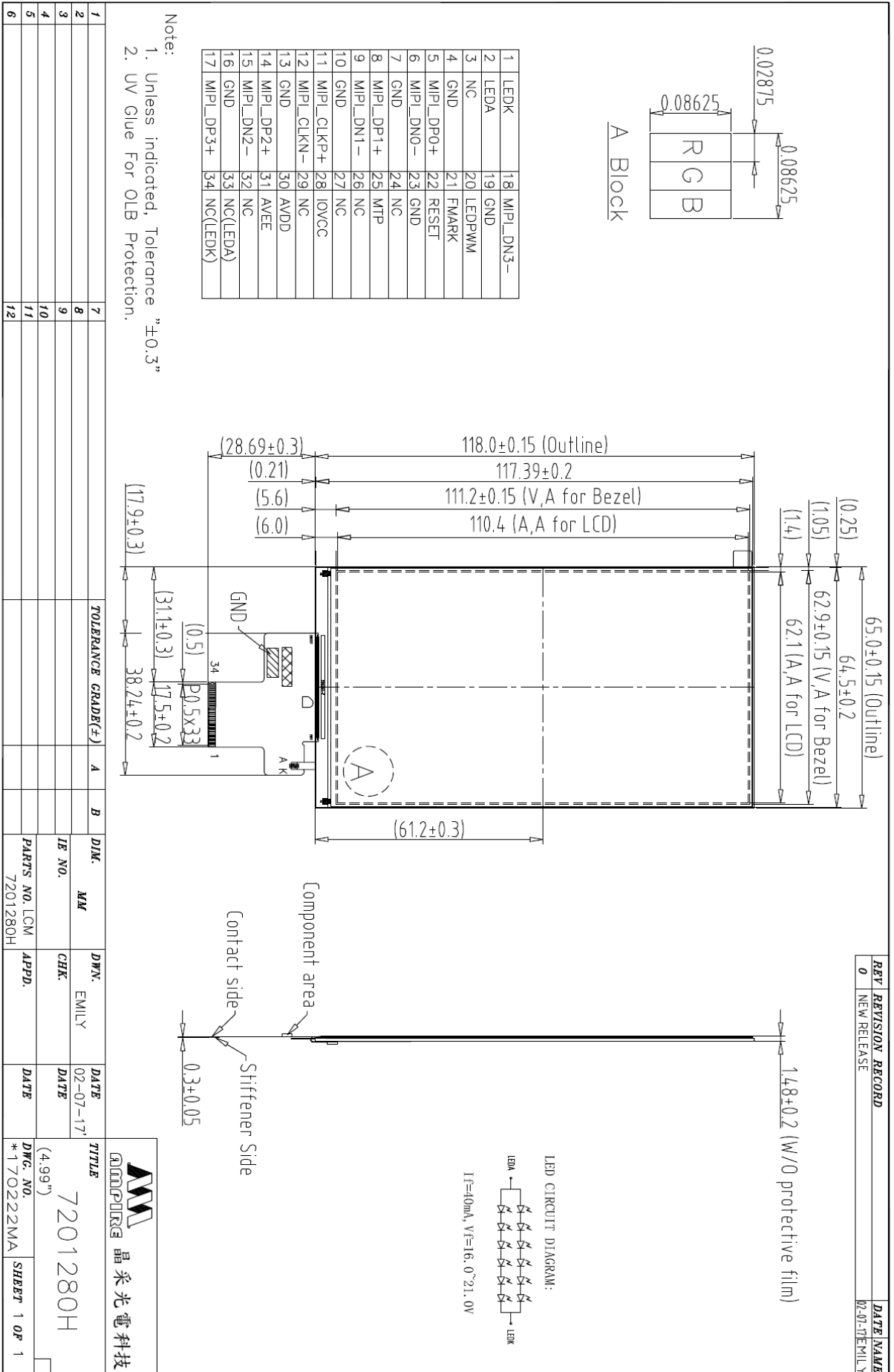

REV	REVISION RECORD	DATE	NAME
0	NEW RELEASE	02-07-17	EMILY

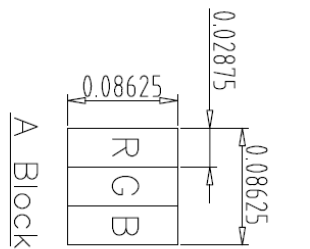

1	LEDK	18	MPL_DN3-
2	LEDA	19	GND
3	NC	20	LEDPWM
4	GND	21	FMARK
5	MPL_DP0+	22	RESET
6	MPL_DN0-	23	GND
7	GND	24	NC
8	MPL_DP1+	25	MTP
9	MPL_DN1-	26	NC
10	GND	27	NC
11	MPL_CLKP+	28	IOVCC
12	MPL_CLKN-	29	NC
13	GND	30	AVDD
14	MPL_DP2+	31	AVEE
15	MPL_DN2-	32	NC
16	GND	33	NC(LEDA)
17	MPL_DP3+	34	NC(LEDK)

Note:
 1. Unless indicated, Tolerance "±0.3"
 2. UV Glue For OLB Protection.

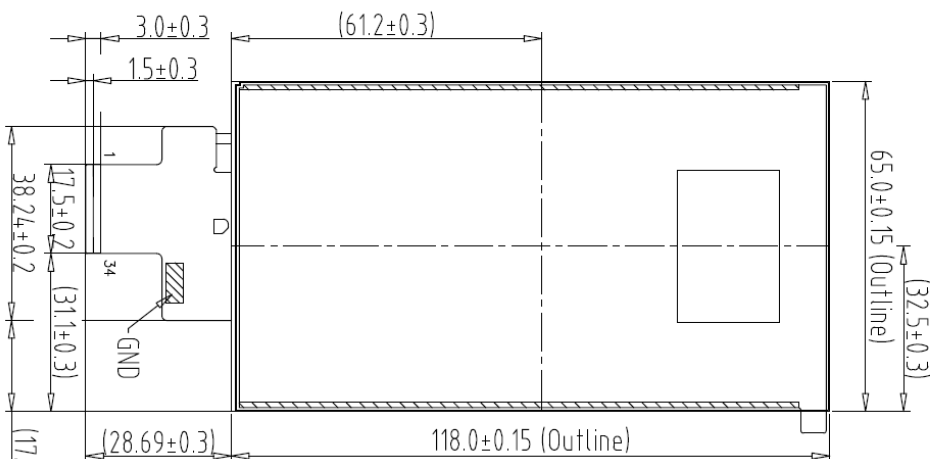

Back View

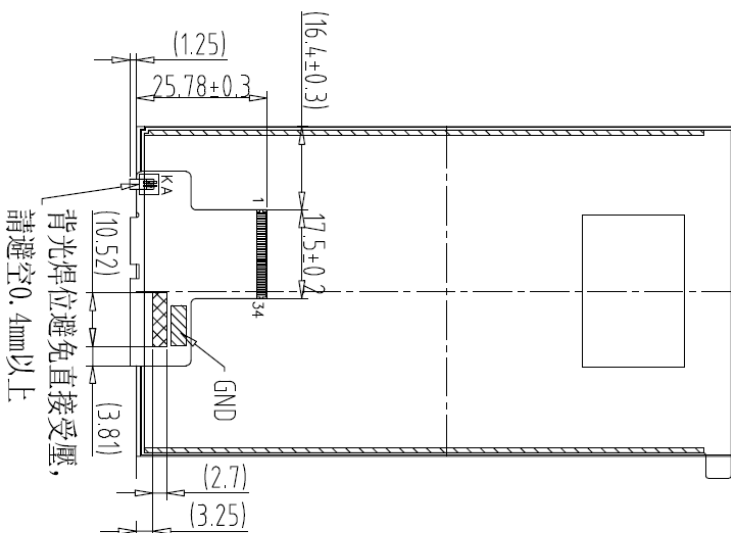

Bending

1	7	TOLERANCE GRADE(±)	A	B	DIM.	MM	DWN.	DATE	TITLE
2	8				IE NO.		EMILY	02-07-17	7201280H
3	9						CHK.	DATE	(4.99")
4	10							DATE	*170223MA
5	11				PARTS NO.	LCM-1	APPD.	DATE	SHEET 1 OF 1
6	12				7201280H				

AMPIRE 晶采光電科技

Our company network supports you worldwide with offices in Germany, Austria, Switzerland, the UK and the USA. For more information please contact:

Headquarters

Germany



FORTEC Elektronik AG

Lechwiesenstr. 9
86899 Landsberg am Lech

Phone: +49 8191 91172-0
E-Mail: sales@forteca.de
Internet: www.forteca.de

Fortec Group Members

Austria



FORTEC Elektronik AG

Office Vienna

Nuschinggasse 12
1230 Wien

Phone: +43 1 8673492-0
E-Mail: office@fortec.at
Internet: www.fortec.at

Germany



Distec GmbH

Augsburger Str. 2b
82110 Germering

Phone: +49 89 894363-0
E-Mail: info@distec.de
Internet: www.distec.de

Switzerland



ALTRAC AG

Bahnhofstraße 3
5436 Würenlos

Phone: +41 44 7446111
E-Mail: info@altrac.ch
Internet: www.altrac.ch

United Kingdom



Display Technology Ltd.

Osprey House, 1 Osprey Court
Hichingbrooke Business Park
Huntingdon, Cambridgeshire, PE29 6FN

Phone: +44 1480 411600
E-Mail: info@displaytechnology.co.uk
Internet: www.displaytechnology.co.uk

USA



Apollo Display Technologies, Corp.

87 Raynor Avenue,
Unit 1 Ronkonkoma,
NY 11779

Phone: +1 631 5804360
E-Mail: info@apolloDisplays.com
Internet: www.apolloDisplays.com