



OUR GLOBAL
COMPETENCE
CENTRES

 APOLLO DISPLAY
TECHNOLOGIES



 DISTEC



 DISPLAY
TECHNOLOGY



Datasheet

Amoled

AL190SXL01-N

AM-01-003

The information contained in this document has been carefully researched and is, to the best of our knowledge, accurate. However, we assume no liability for any product failures or damages, immediate or consequential, resulting from the use of the information provided herein. Our products are not intended for use in systems in which failures of product could result in personal injury. All trademarks mentioned herein are property of their respective owners. All specifications are subject to change without notice.



Product Specification

- () Preliminary Specification
- (●) Final Specification

Model Name: AL190SXL01-N

Product Name: 19 inch 1280 x 1024 TFT LCD Module

Customer	
Approved By	Date
_____	_____
_____	_____

AMOLED Corporation	
Approved By	Date
_____	_____
Prepared By	Date
Stanley	08 Dec. 2015
_____	_____



Contents

1. General Description	4
1.1 Specifications	4
2. Mechanical Drawing.....	5
3. Pin Assignment.....	7
3.1 TFT LCD Module	7
3.2 Backlight Unit	8
4. Absolute Maximum Ratings	9
4.1 TFT LCD Module	9
4.2 Absolute Ratings of Environment.....	9
5. Electrical Characteristics	10
5.1 TFT LCD Module	10
5.1.1 Power Specification.....	10
5.1.2 Signal Electrical Characteristics.....	11
5.1.3 Backlight Unit	12
5.2 Signal Characteristic.....	13
5.2.1 Pixel Format Image.....	13
5.2.2 The Input Data Format	13
5.3 Interface Timing	14
5.3.1 Timing Characteristics.....	14
5.3.2 Timing Diagram	14
5.4 Power ON/OFF Sequence.....	15
6. Connector.....	16
6.1 TFT LCD Module	16
6.2 Backlight Unit	16
7. Block Diagram	16
8. Optical Characteristics.....	17
9. Precautions.....	20
10. Reliability Test	21



History of Revision

Version	Date	Page	Description	Remark
1.00	08 Dec. 2015		Final Version	

AC Confidential Document

This document contains confidential and proprietary information of AMOLED Corporation. Neither it nor the information contained herein shall be disclosed to others or duplicated or used for others without the express written consent of AMOLED Corporation.



1. General Description

AL190SXL01-N is a Color Active Matrix Liquid Crystal Display composed of a TFT-LCD panel, a driver circuit, and a backlight system. The screen format is intended to support the SXGA (1280(H) x 1024(V)) screen and 16.7M colors (RGB 6-bits + Hi_FRC data). All input signals are 2-channel LVDS interface.

1.1 Specifications

The following items are characteristics summary on the table under 25 °C condition:

Item	Unit	Specification
Screen Diagonal	[mm]	482.6 (19.0")
Active Area	[mm]	376.32 (H) x 301.06 (V)
Pixels H x V	-	1280(RGB) x 1024
Pixel Pitch	[mm]	0.294 x 0.294
Pixel Arrangement	-	R.G.B. Vertical Stripe
Display Mode	-	Normally White
White Luminance	[cd/m ²]	1000 (center, Typ.) @90mA
Contrast Ratio	-	1000 : 1 (Typ.)
Optical Response Time	[ms]	10 ms (Typ., on/off)
Nominal Input Voltage VDD	[Volt]	+5.0 V
Power Consumption	[Watt]	23.52 W (Typ.)
Weight	[Grams]	1800 (Typ.)
Physical Size (H x V x D)	[mm]	396 (H) x 324 (V) x 15.18(D) (Typ.)
Electrical Interface	-	Dual channel LVDS
Surface Treatment	-	Anti-glare, Hardness 3H
Support Color	-	16.7M colors (RGB 6-bit + Hi_FRC)
Temperature Range	[°C] [°C]	-30 to +85 → Operating -30 to +85 → Storage (Non-Operating)
RoHS Compliance	-	RoHS Compliance



2. Mechanical Drawing

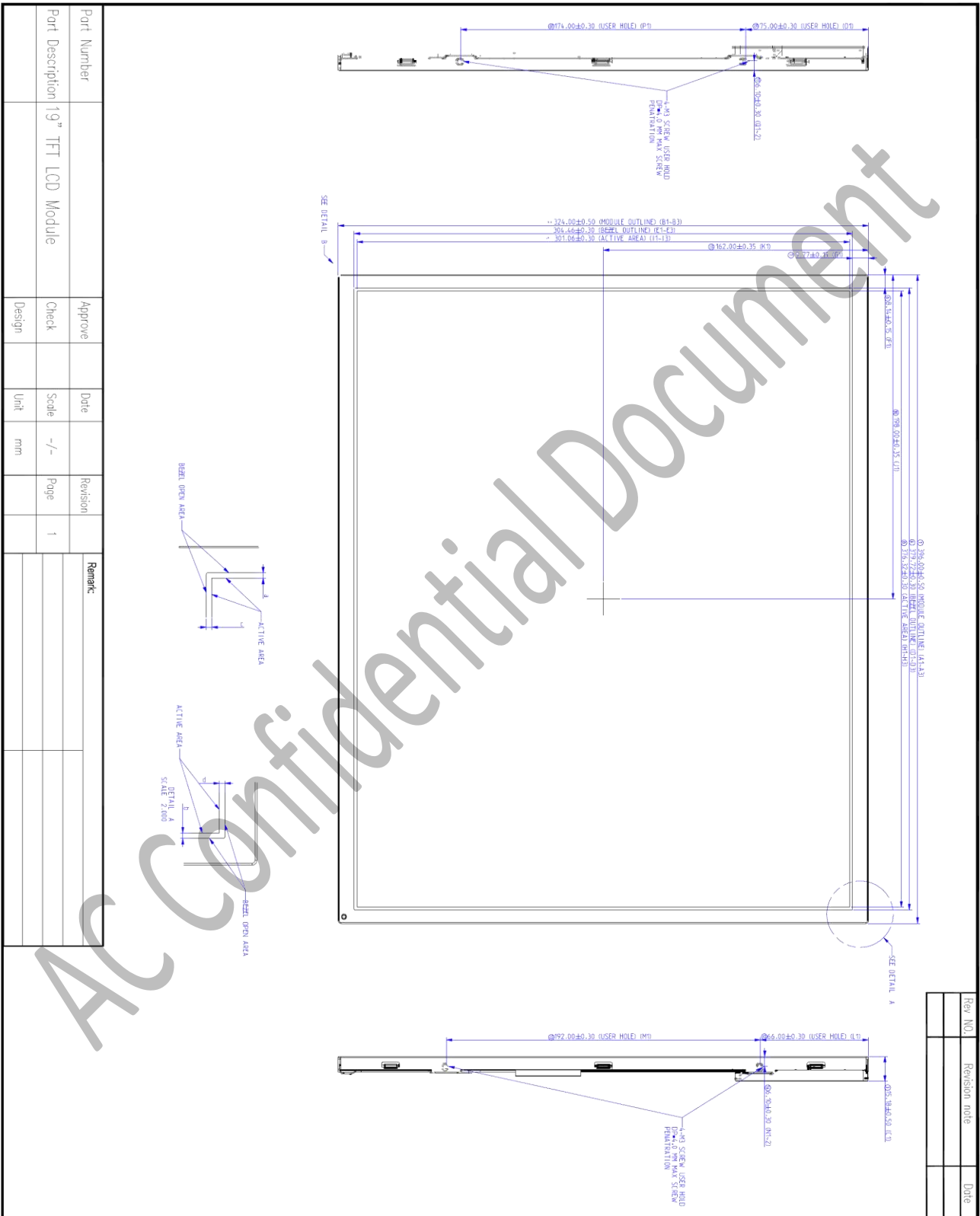

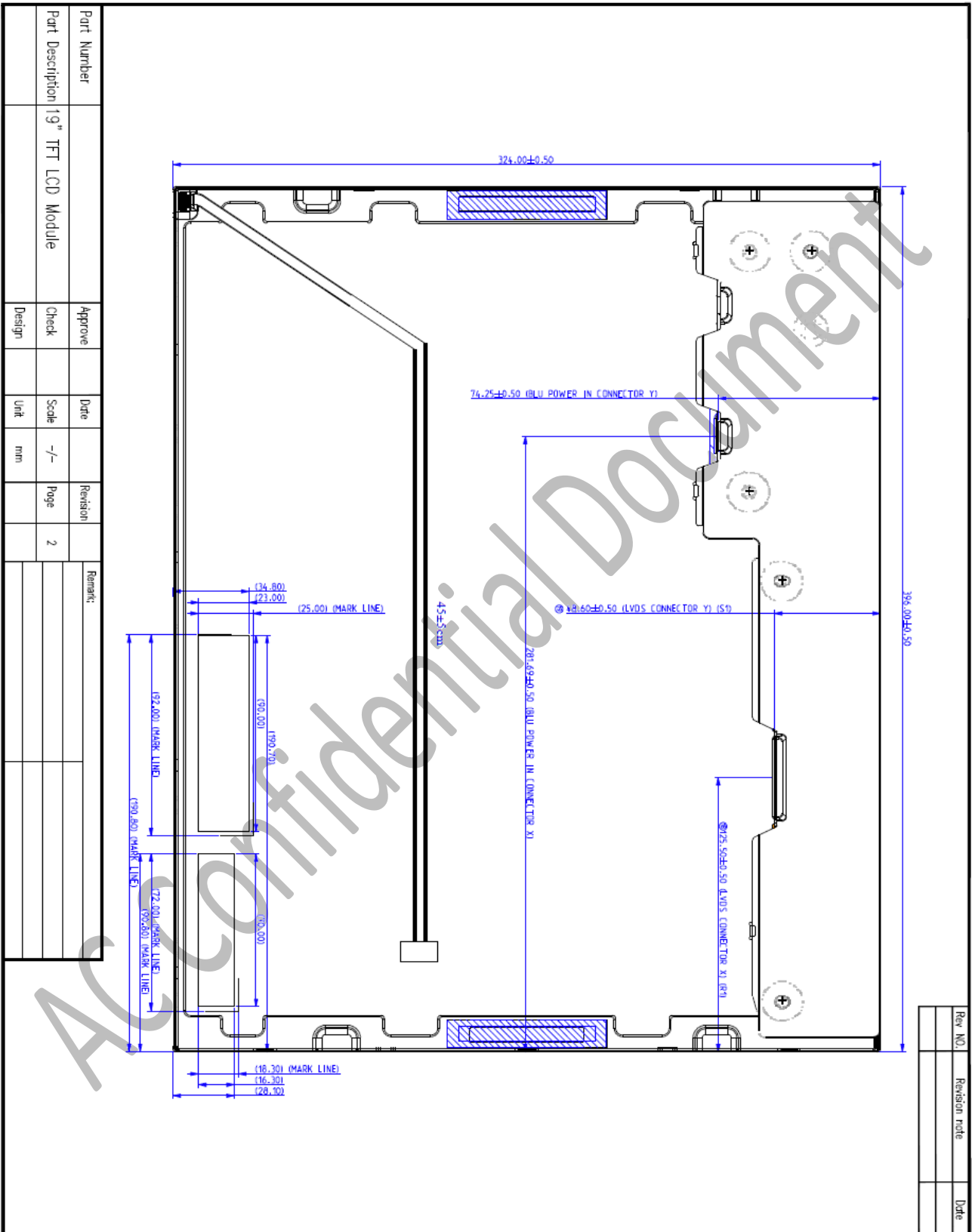



3. Pin Assignment

The module using one LVDS receiver SN75LVDS82 (Texas Instruments). LVDS is a differential signal technology for LCD interface and high speed data transfer device. LVDS transmitters shall be SN75LVDS83 (negative edge sampling). The first LVDS port (RxOxxx) transmits odd pixels while the second LVDS port (RxExxx) transmits even pixels.

3.1 TFT LCD Module

Pin No.	Signal Name	Description
1	RxOIN0-	Negative LVDS differential data input (Odd data)
2	RxOIN0+	Positive LVDS differential data input (Odd data)
3	RxOIN1-	Negative LVDS differential data input (Odd data)
4	RxOIN1+	Positive LVDS differential data input (Odd data)
5	RxOIN2-	Negative LVDS differential data input (Odd data, DSPTMG)
6	RxOIN2+	Positive LVDS differential data input (Odd data, DSPTMG)
7	GND	Power Ground
8	RxOCLKIN-	Negative LVDS differential clock input (Odd clock)
9	RxOCLKIN+	Positive LVDS differential clock input (Odd clock)
10	RxOIN3-	Negative LVDS differential data input (Odd data)
11	RxOIN3+	Positive LVDS differential data input (Odd data)
12	RxEIN0-	Negative LVDS differential data input (Even data)
13	RxEIN0+	Positive LVDS differential data input (Even data)
14	GND	Power Ground
15	RxEIN1-	Positive LVDS differential data input (Even data)
16	RxEIN1+	Negative LVDS differential data input (Even data)
17	GND	Power Ground
18	RxEIN2-	Negative LVDS differential data input (Even data)
19	RxEIN2+	Positive LVDS differential data input (Even data)
20	RxECLKIN-	Negative LVDS differential clock input (Even clock)
21	RxECLKIN+	Positive LVDS differential clock input (Even clock)
22	RxEIN3-	Negative LVDS differential data input (Even data)
23	RxEIN3+	Positive LVDS differential data input (Even data)
24	GND	Power Ground
25	GND	Power Ground
26	GND	Power Ground
27	GND	Power Ground
28	POWER	Power +5V
29	POWER	Power +5V
30	POWER	Power +5V



3.2 Backlight Unit

Pin No.	Symbol	Description
1 (red)	VLED	Anode
2 (white)	GND	Cathode

Note1: "Power Ground" stands for 0V

Note2: Start from left side

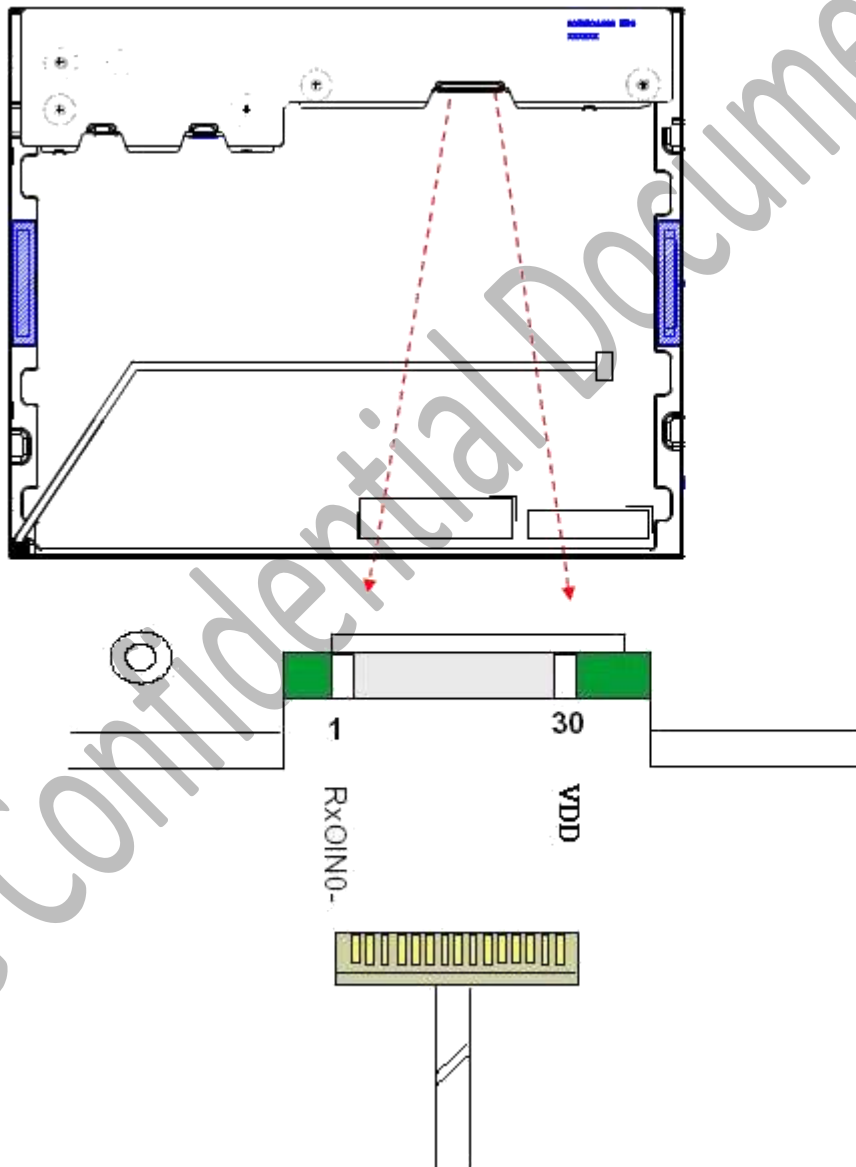

Note3: Input signals of odd and even clock shall be the same timing.



4. Absolute Maximum Ratings

Absolute maximum ratings of the module are as following:

4.1 TFT LCD Module

Item	Symbol	Min	Max	Unit	Conditions
Logic/LCD Drive	VDD	-0.3	+6.0	[Volt]	Note 1,2

4.2 Absolute Ratings of Environment

Item	Symbol	Min.	Max.	Unit	Conditions
Operating	TOP	-30	+85	[°C]	Note 3
Operation Humidity	HOP	5	95	[%RH]	Note 3
Storage Temperature	TST	-30	+85	[°C]	
Storage Humidity	HST	5	95	[%RH]	

Note 1: With in Ta (25°C)

Note 2: Permanent damage to the device may occur if exceeding maximum values

Note 3: Temperature and relative humidity range are shown as the below figure.

1. 95% RH Max (Ta ≤ 39°C)
2. Max wet-bulb temperature at 39°C or less. (Ta ≤ 39°C)
3. No condensation

Note 4: Function Judged only

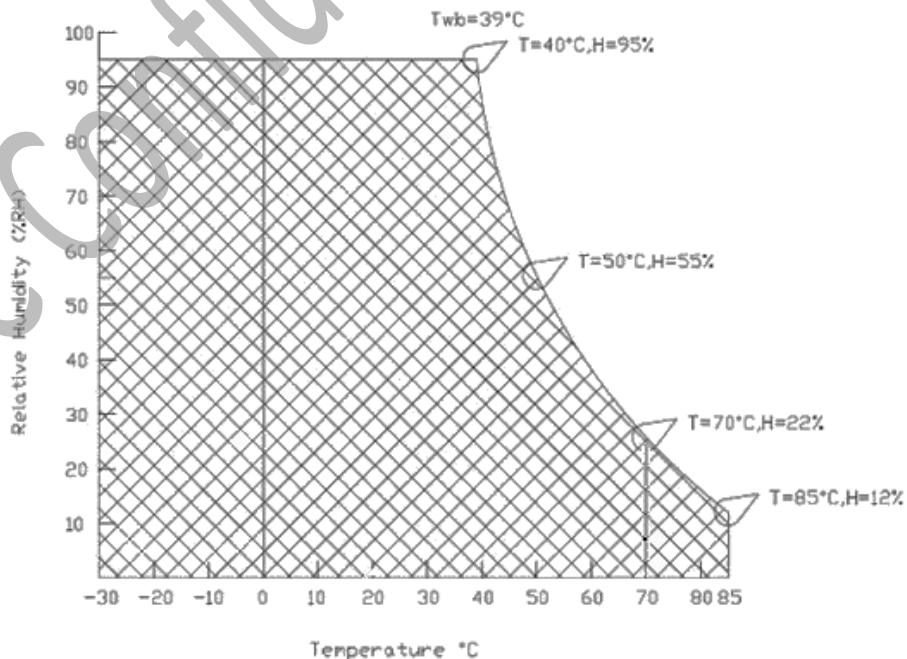

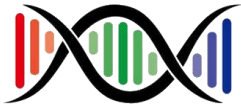

5. Electrical Characteristics

5.1 TFT LCD Module

5.1.1 Power Specification

Input power specifications are as follows:

Symbol	Parameter	Min.	Typ.	Max.	Unit	Conditions
VDD	Logic/LCD Drive	4.5	5.0	5.5	[Volt]	+/-10%
IDD	Input Current	-	1	1.2	[A]	VDD= 5.0V, All Black Pattern At 75Hz
PDD	VDD Power	-	5	6	[Watt]	VDD= 5.0V, All Black Pattern At 75Hz
IRush	Inrush Current	-	-	3.0	[A]	Note 1
VDDrp	Allowable Logic/LCD Drive	-	-	100	[mV] p-p	VDD= 5.0V, All Black Pattern At 75Hz

Note 1: Measurement conditions:

The duration of rising time of power input is 470us.

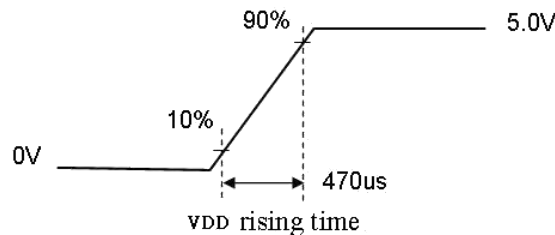
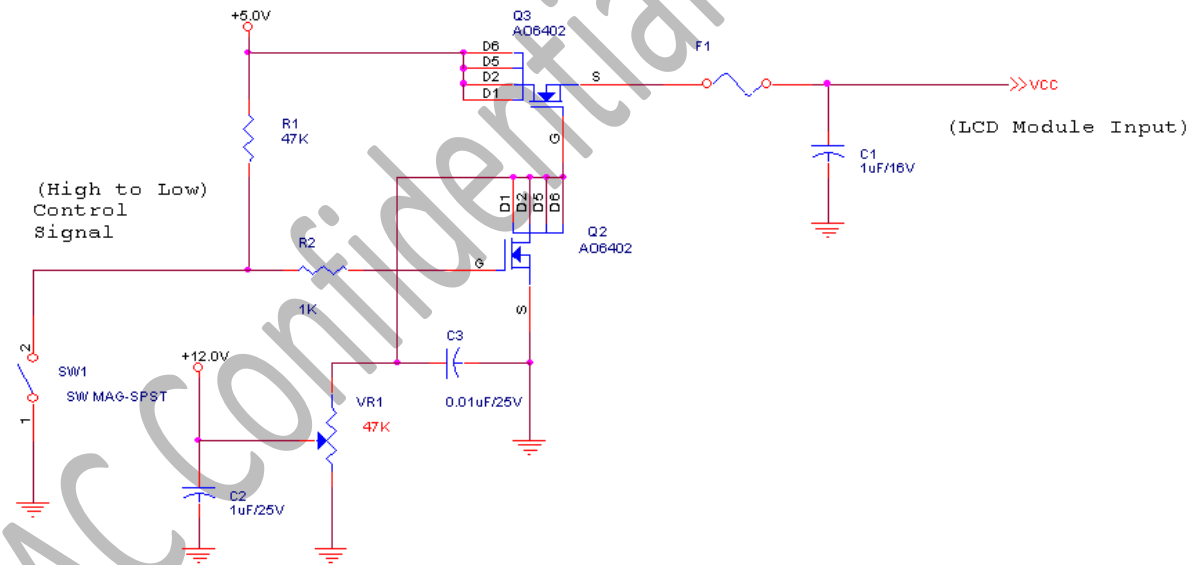



5.1.2 Signal Electrical Characteristics

Input signals shall be low or Hi-Z state when VDD is off. Please refer to specifications of SN75LVDS82DGG (Texas Instruments) in detail.

Each signal characteristics are as follows:

Symbol	Parameter	Min	Typ	Max	Units	Condition
V _{TH}	Differential Input High Threshold	-	-	+100	[mV]	V _{CM} = 1.2V Note 1
V _{TL}	Differential Input Low Threshold	-100	-	-	[mV]	V _{CM} = 1.2V Note 1
V _{ID}	Input Differential Voltage	100	400	600	[mV]	Note 1
V _{CM}	Differential Input Common Mode Voltage	+1.0	+1.2	+1.5	[V]	V _{TH} -V _{TL} = 200mV Note 1

Note1: LVDS Signal Waveform

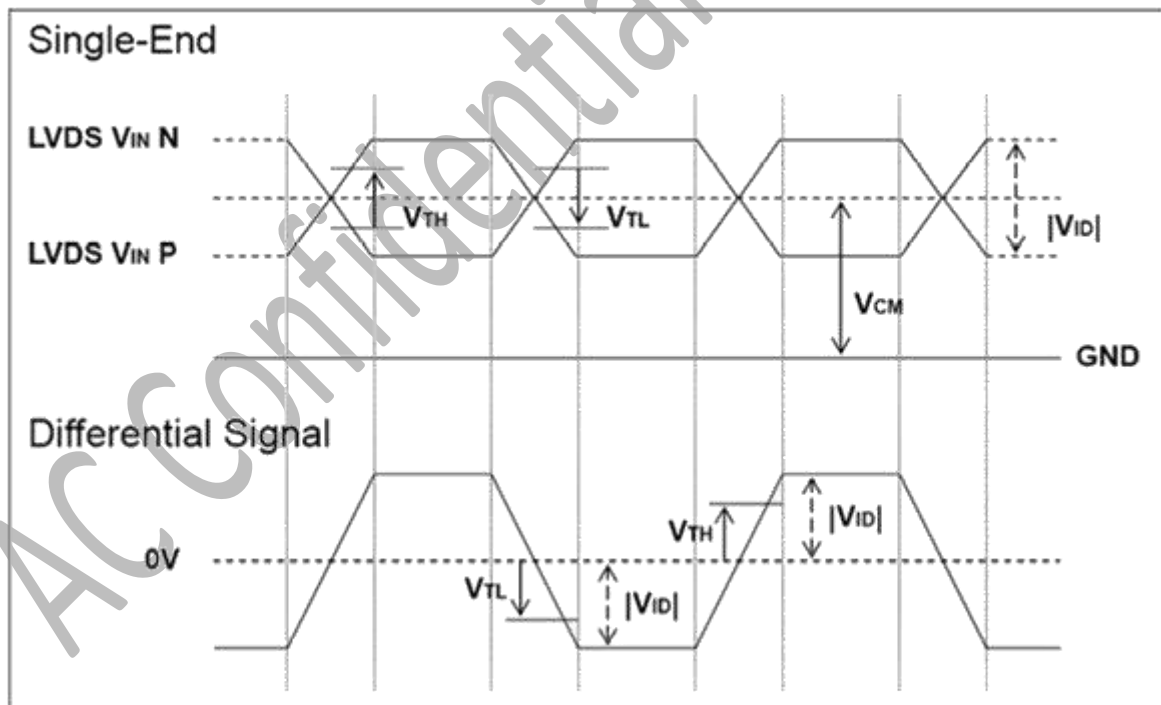



5.1.3 Backlight Unit

Parameter guideline for LED driving is under stable conditions at 25 °C (Room Temperature):

IF	LED Forward Current	-	630	-	[mA]	Ta = 25°C
VF	LED Forward Voltage	-	-	-	[Volt]	I = 630mA, Ta = 0°C
		28	29.4	38	[Volt]	I = 630mA, Ta = 25°C
		-	-	-	[Volt]	I = 630mA, Ta = 70°C
PLED	LED Power	-	18.52	-	[Watt]	-
LED Life Time	-	50,000	-	-	Hrs	I = 630mA, Ta = 25°C

Note 1: Ta means ambient temperature of TFT-LCD module.

Note 2: IF, VF are defined for one channel LED.

Note 3: If AL190SXL01-N module is driven by high current or at high ambient temperature & humidity condition. The operating life will be reduced.

Note 4: Operating life means brightness goes down to 50% initial brightness. Minimum operating life time is estimated data.

Note 5: LED lifetime is definition: brightness is decreased to 50% of the initial value. LED lifetime is restricted under normal condition, ambient temperature = 25 °C and LED operating IF = 90mA.



5.2 Signal Characteristic

5.2.1 Pixel Format Image

Following figure shows the relationship of the input signals and LCD pixel format.

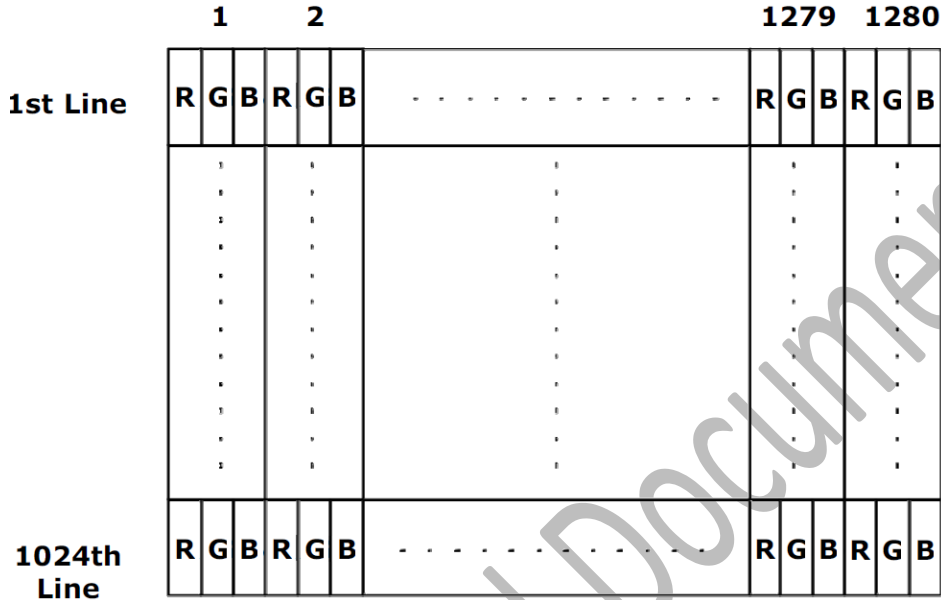

5.2.2 The Input Data Format

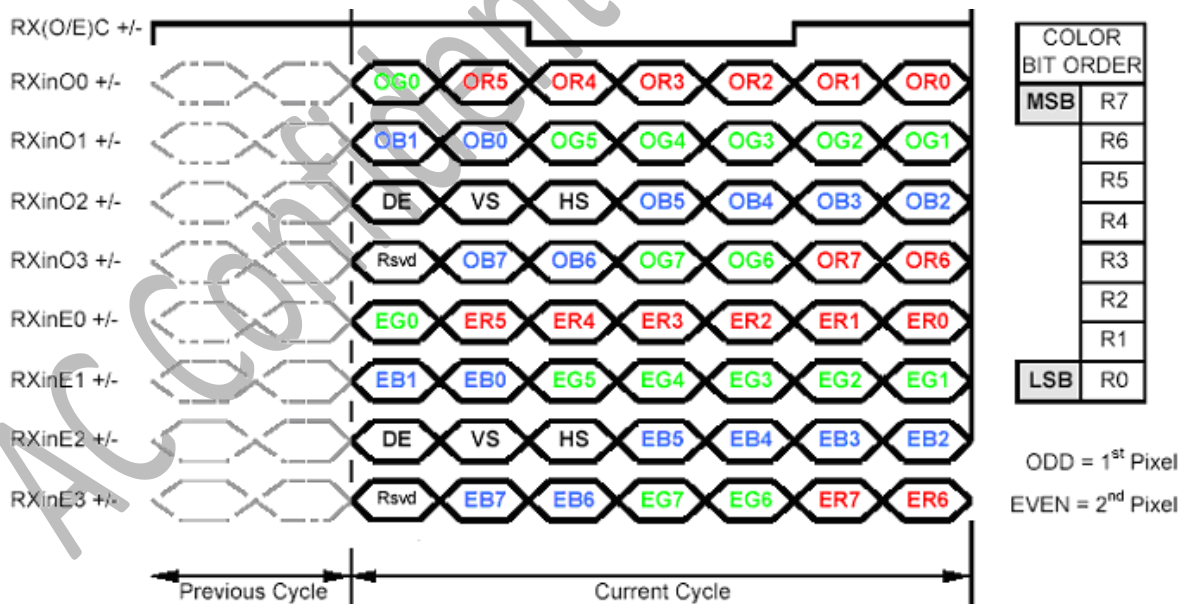

Note1: DE only, VS, HS on EVEN channel are not used.

Note2: Please follow PSWG.

Note3: 8-bit in



5.3 Interface Timing

5.3.1 Timing Characteristics

Signal	Item	Symbol	Min	Typ	Max	Unit
Vertical Section	Period	T_v	1032	1066	1150	Th
	Active	$T_{disp}(v)$	1024	1024	1024	Th
	Blanking	$T_{bp}(v)+T_{fp}(v)+PW_{vs}$	8	42	126	Th
Horizontal Section	Period	T_h	780	844	2047	Tclk
	Active	$T_{disp}(h)$	640	640	640	Tclk
	Blanking	$T_{bp}(h)+T_{fp}(h)+PW_{hs}$	140	204	-	Tclk
Clock	Period	T_{clk}	22.2	18.52	14.81	ns
	Frequency	Freq.	44	54	67.5	MHz
Frame Rate	Frequency	$1/T_v$	49	60	75	Hz

Note: DE mode only

5.3.2 Timing Diagram

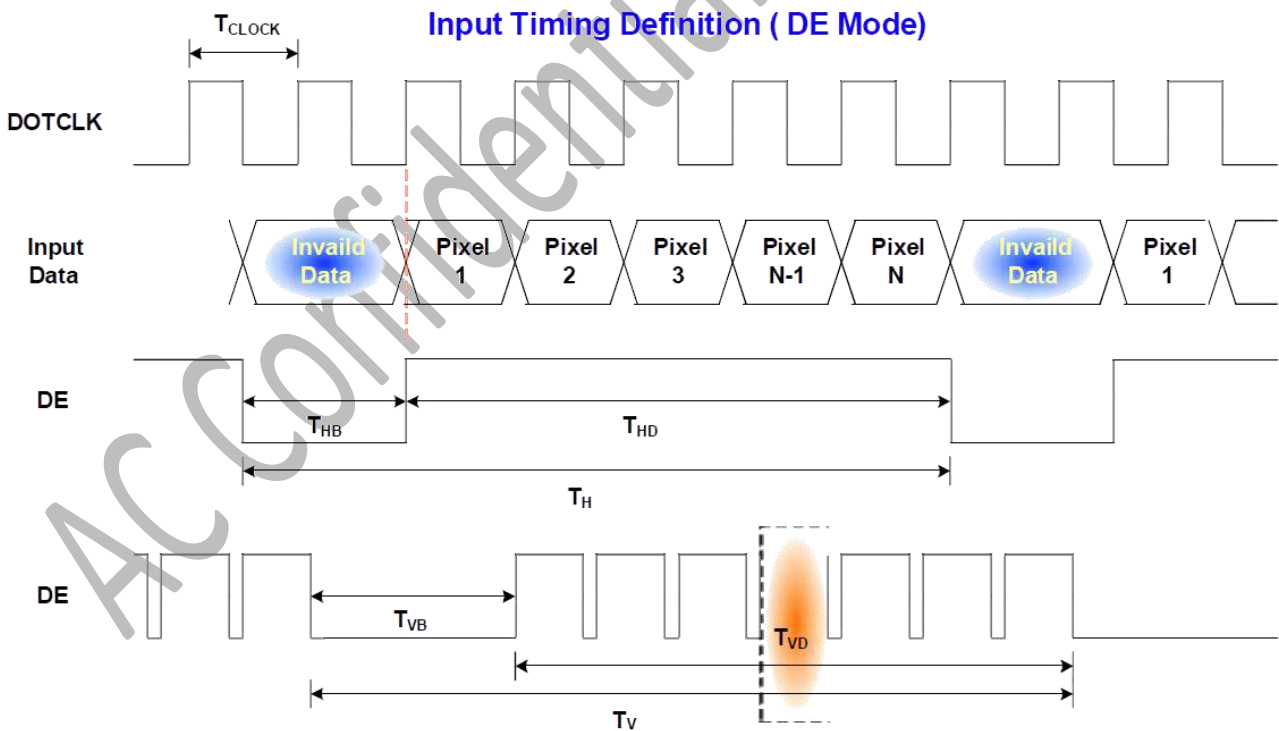



5.4 Power ON/OFF Sequence

VDD power and lamp on/off sequence are as follows. Interface signals are also shown in the chart. Signals from any system shall be Hi-Z state or low level when VDD is off.

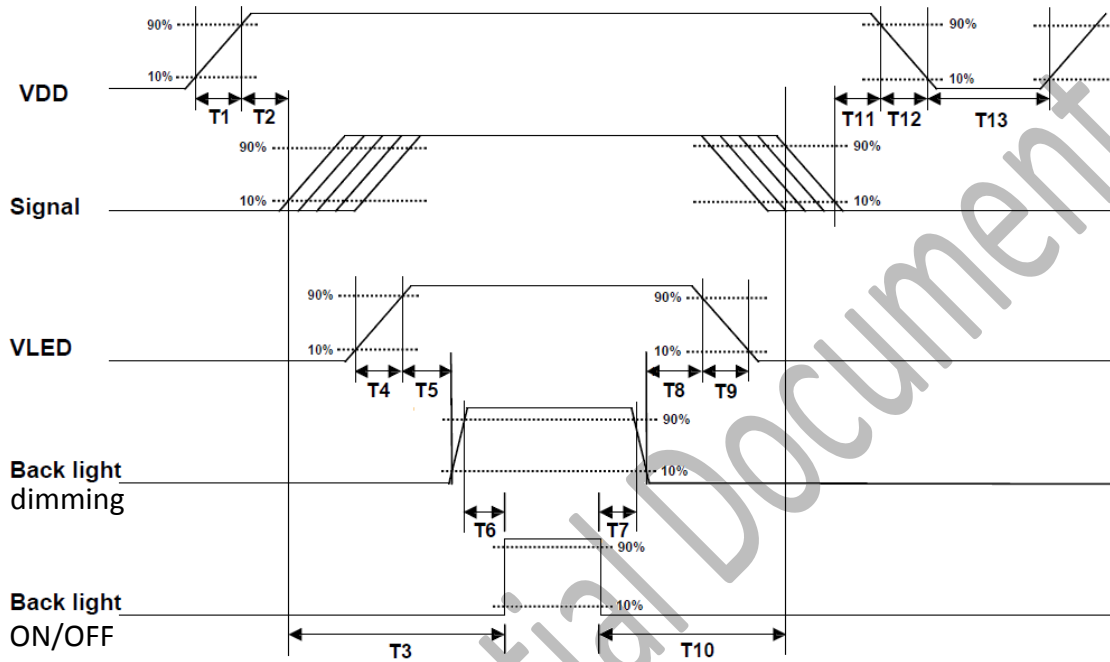

Parameter	Min.	Typ.	Max.	Unit
T1	0.5	-	10	ms
T2	30	40	50	ms
T3	200	-	-	ms
T4	0.5	-	10	ms
T5	10	-	-	ms
T6	10	-	-	ms
T7	0	-	-	ms
T8	10	-	-	ms
T9	-	-	10	ms
T10	110	-	-	ms
T11	0	16	50	ms
T12	-	-	10	ms
T13	1000	-	-	ms



6. Connector

Physical interface is described as for the connector on module. These connectors are capable of accommodating the following signals and will be following components.

6.1 TFT LCD Module

Connector Name / Designation	Interface Connector / Interface card
Manufacturer	HRS
Type Part Number	DF14H-30P-1.25H
Mating Housing Part Number	DF14-30S-1.25C

6.2 Backlight Unit

Physical interface is described as for the connector on module. These connectors are capable of accommodating the following signals and will be following components.

Connector Name / Designation	Light Bar Connector
Manufacturer	JST
Type Part Number	PHR-2
Mating Housing Part Number	S2B-PH-SM4-TB

7. Block Diagram

The following diagram shows the functional block of the 19.0 inches wide Color TFT-LCD Module:

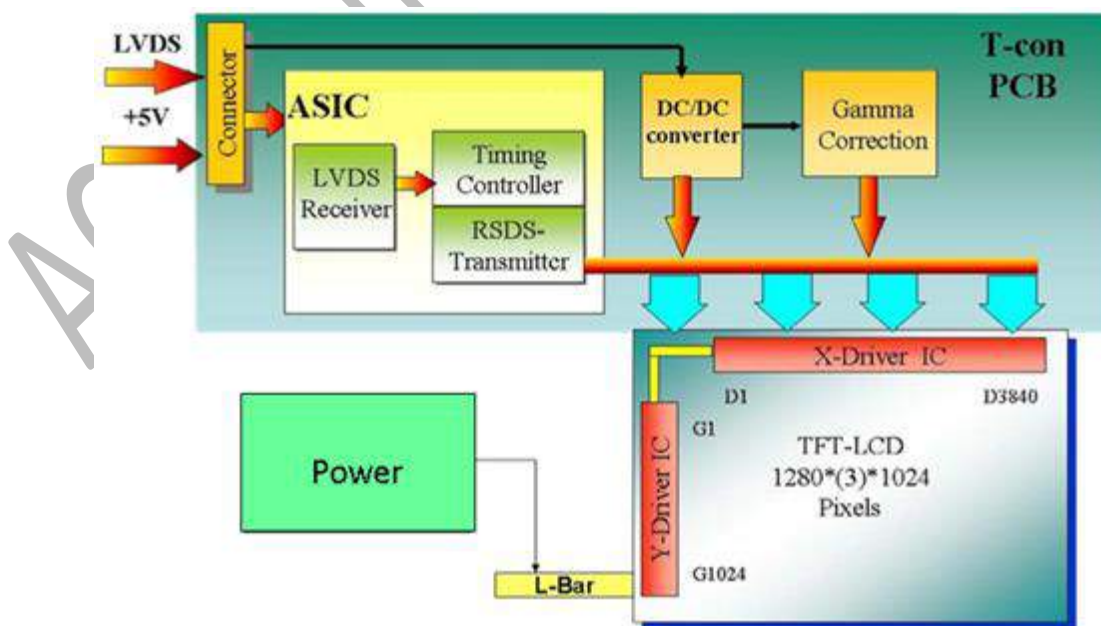



8. Optical Characteristics

The optical characteristics are measured under stable conditions at 25°C (Room Temperature).

Item	Unit	Conditions	Min.	Typ.	Max.	Note
Viewing Angle	[degree]	Horizontal (Right)	75	85	-	1
		CR = 10 (Left)	75	85		
		Vertical (Up)	70	80	-	
		CR = 10 (Down)	70	80		
Contrast Ratio	-	Normal Direction	600	1000	-	-
Central Luminance	[cd/m ²]	-	800	1000	-	2
Optical Response Time	[ms]	Raising Time (TrR)	-	7	12	3
		Falling Time (TrF)	-	3	8	
		Rising + Falling	-	10	20	
Color / Chromaticity Coordinates (CIE)	-	Red x	0.590	0.640	0.690	-
		Red y	0.294	0.344	0.394	
		Green x	0.277	0.327	0.377	
		Green y	0.574	0.624	0.674	
		Blue x	0.105	0.155	0.205	
		Blue y	0.004	0.054	0.104	
		White x	0.263	0.313	0.363	
White y	0.279	0.329	0.379			
Luminance Uniformity	[%]	9 Points	75	80	-	4,5
NTSC	[%]	-	-	70	-	-

Optical Equipment: BM-5A, BM-7, PR880, or equivalent



Note 1: Definition of viewing angle

Viewing angle is the measurement of contrast ratio ≥ 10 , or ≥ 5 , at the screen center, over a 180° horizontal and 180° vertical range (off-normal viewing angles). The 180° viewing angle range is broken down as follows; 90° (θ) horizontal left and right and 90° (Φ) vertical, high (up) and low (down). The measurement direction is typically perpendicular to the display surface with the screen rotated about its center to develop the desired measurement viewing angle.

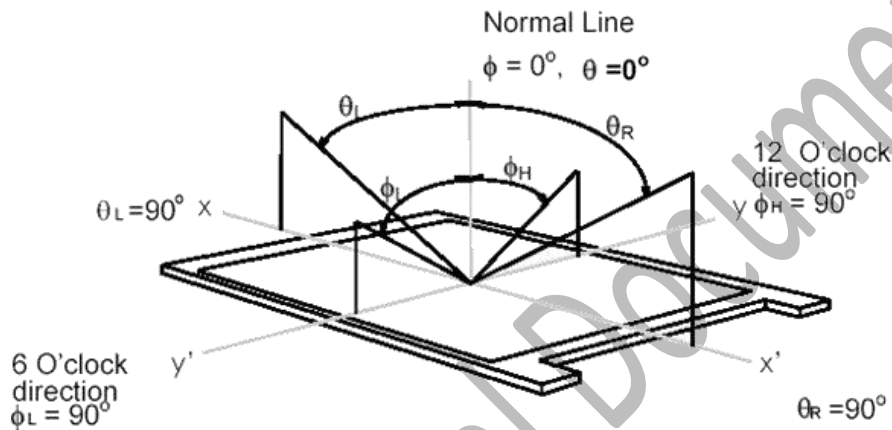

Note 2: Measurement method

The LCD module should be stabilized at given temperature for 30 minutes to avoid abrupt temperature change during measuring. In order to stabilize the luminance, the measurement should be executed after lighting Backlight for 30 minutes in a stable, windless and dark room.

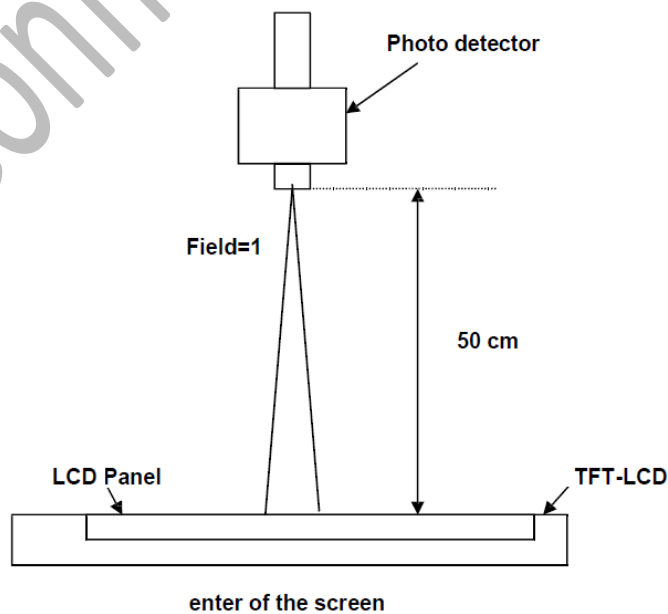



Note 3: Definition of response time:

The output signals of photo detector are measured when the input signals are changed from “Full Black” to “Full White” (rising time), and from “Full White” to “Full Black” (falling time), respectively. The response time is interval between the 10% and 90% of amplitudes. Please refer to the figure as below.

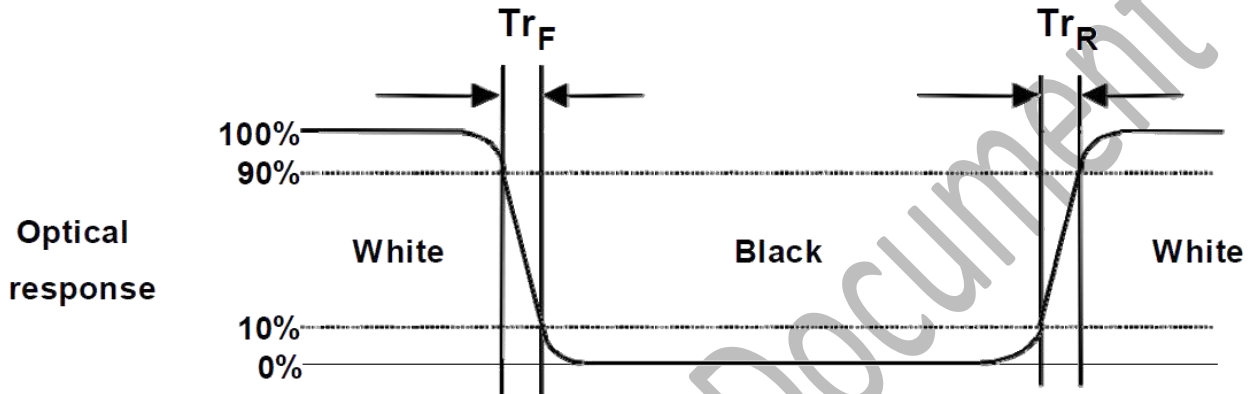

Note 4: 9-point position

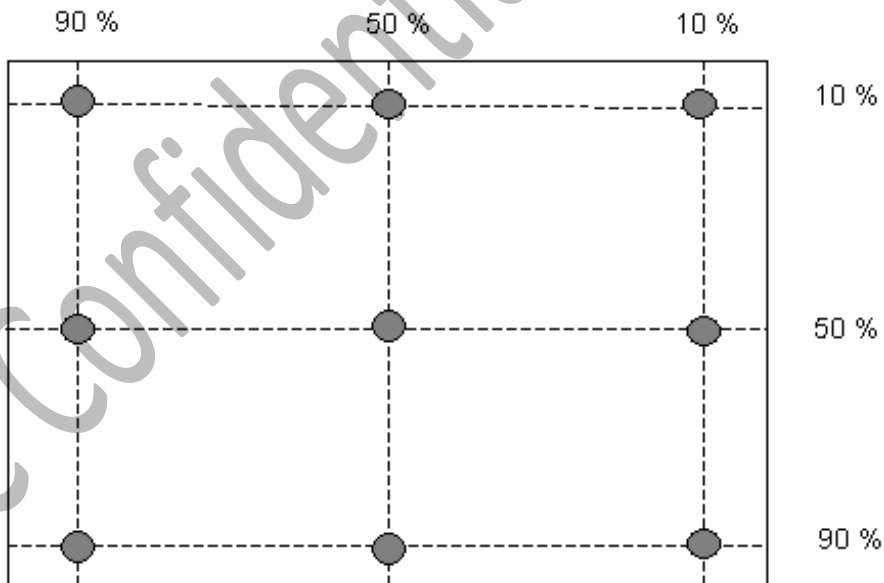

Note 5:

$$\text{Uniformity} = \frac{\text{Minimum Luminance in 9 points}}{\text{Maximum Luminance in 9 points}}$$



9. Precautions

- 1) Since front polarizer is easily damaged, please be cautious and not to scratch it.
- 2) Be sure to turn off power supply when inserting or disconnecting from input connector.
- 3) Wipe off water drop immediately. Long contact with water may cause discoloration or spots.
- 4) When the panel surface is soiled, wipe it with absorbent cotton or soft cloth.
- 5) Since the panel is made of glass, it may be broken or cracked if dropped or bumped on hard surface.
- 6) To avoid ESD (Electro Static Discharge) damage, be sure to ground yourself before handling TFT-LCD Module.
- 7) Do not open nor modify the module assembly.
- 8) Do not press the reflector sheet at the back of the module to any direction.
- 9) In case if a module has to be put back into the packing container slot after it was taken out from the container, do not press the center of the LED light bar edge. Instead, press at the far ends of the LED light bar edge softly. Otherwise the TFT Module may be damaged.
- 10) At the insertion or removal of the Signal Interface Connector, be sure not to rotate nor tilt the Interface Connector of the TFT Module.
- 11) TFT-LCD Module is not allowed to be twisted & bent even force is added on module in a very short time. Please design your display product well to avoid external force applying to module by end-user directly.
- 12) Small amount of materials without flammability grade are used in the TFT-LCD module. The TFT-LCD module should be supplied by power complied with requirements of Limited Power Source (IEC60950 or UL1950), or be applied exemption.
- 13) Severe temperature condition may result in different luminance, response time and lamp ignition voltage.
- 14) Continuous operating TFT-LCD display under low temperature environment may accelerate lamp exhaustion and reduce luminance dramatically.
- 15) The data on this specification sheet is applicable when LCD module is placed in landscape position.
- 16) Continuous displaying fixed pattern may induce image sticking. It's recommended to use screen saver or shuffle content periodically if fixed pattern is displayed on the screen.



10. Reliability Test

Environment test conditions are listed as following table.

Item	Condition	Note
Temperature Humidity Bias (THB)	Ta=50°C, 80%RH, 240hours	-
High Temperature Operation (HTO)	Ta=85°C, 240hours	1
Low Temperature Operation (LTO)	Ta=-30°C, 240hours	1
HighTemperatureStorage (HTS)	Ta=85°C, 240hours	1
LowTemperatureStorage (LTS)	Ta=-30°C, 240hours	1
Vibration Test (Non- operation)	Acceleration: 1.5 G Wave: Random Frequency: 10 - 200 - 10 Hz Sweep: 30 Minutes each Axis (X, Y, Z)	-
Shock Test (Non- operation)	Acceleration: 50 G Wave: Half-sine Active Time: 20 ms Direction: ±X, ±Y, ±Z (one time for each Axis)	-
DropTest	Height: 61 cm, package test	-
Thermal Shock Test (TST)	-20°C/30min, 60°C/30min, 50cycles	-
ESD (Electro-Static Discharge)	Contact Discharge: ± 8KV, 150pF (330Ω) 1sec, 9 points, 25 times/ point.	2
	Air Discharge: ± 15KV, 150pF (330Ω) 1sec, 9 points, 25 times/ point.	

Note1: No function failure occurs.

Note2: According to EN61000-4-2, ESD class B: Some performance degradation allowed. No data lost
Self- recoverable. No hardware failures.

Note3:

- Water condensation is not allowed for each test items.
- Each test is done by new TFT-LCD module. Don't use the same TFT-LCD module repeatedly for reliability test.
- The reliability test is performed only to examine the TFT-LCD module capability.
- To inspect TFT-LCD module after reliability test, please store it at room temperature and room humidity for 24 hours at least in advance.

Our company network supports you worldwide with offices in Germany, Austria, Switzerland, the UK and the USA. For more information please contact:

Headquarters

Germany



FORTEC Elektronik AG

Lechwiesenstr. 9
86899 Landsberg am Lech

Phone: +49 8191 91172-0
E-Mail: sales@forteca.de
Internet: www.forteca.de

Fortec Group Members

Austria



FORTEC Elektronik AG

Office Vienna

Nuschinggasse 12
1230 Wien

Phone: +43 1 8673492-0
E-Mail: office@fortec.at
Internet: www.fortec.at

Germany



Distec GmbH

Augsburger Str. 2b
82110 Germering

Phone: +49 89 894363-0
E-Mail: info@distec.de
Internet: www.distec.de

Switzerland



ALTRAC AG

Bahnhofstraße 3
5436 Würenlos

Phone: +41 44 7446111
E-Mail: info@altrac.ch
Internet: www.altrac.ch

United Kingdom



Display Technology Ltd.

Osprey House, 1 Osprey Court
Hichingbrooke Business Park
Huntingdon, Cambridgeshire, PE29 6FN

Phone: +44 1480 411600
E-Mail: info@displaytechnology.co.uk
Internet: www.displaytechnology.co.uk

USA



Apollo Display Technologies, Corp.

87 Raynor Avenue,
Unit 1 Ronkonkoma,
NY 11779

Phone: +1 631 5804360
E-Mail: info@apolloDisplays.com
Internet: www.apolloDisplays.com